

# GILBERT

REG. U.S. PAT. OFF.

# BOY ENGINEERING

For 1922

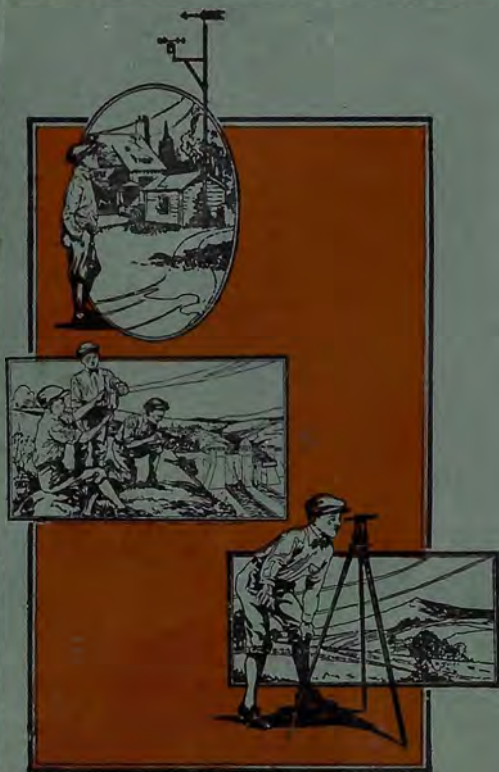

Price 10 Cents

# GILBERT BOY ENGINEERING

Containing

PERSONAL LETTER TO GILBERT BOYS EVERYWHERE, by Alfred C. Gilbert,  
President, The A. C. Gilbert Company.

THE HISTORY OF GILBERT TOYS, by A. C. Gilbert.

HOW TO HIGH JUMP, by A. C. Gilbert.

MEN AND EVENTS IN THE HISTORY OF 1920 SPORTS.

WORLD'S FAMOUS ENGINEERING ACHIEVEMENTS.

HOW TO MAKE WORKING DRAWINGS, by A. Frederick Collins.

THE THEORY OF WIRELESS, by A. Frederick Collins.

CHEMISTRY EXPERIMENTS AND HOW TO PERFORM THEM, by Wm. J.  
Horn, Ph.B., Yale University, 1915.

SOME SIMPLE MAGIC EXPERIMENTS AND HOW TO PERFORM THEM.

General Catalog of  
Gilbert Toys

Published by

**THE A. C. GILBERT COMPANY**  
NEW HAVEN, CONNECTICUT

In Canada:—The A. C. Gilbert-Menzies Co., Limited, Toronto  
In England:—The A. C. Gilbert Co., 125 High Holborn, London, W. C. I.



**Hello Boys!**  
THE GILBERT CO.

I suppose I have more boy friends in the world than any other single individual, and I am very proud of it. Every day the mail brings me letters from boys in all parts of the United States, from Maine to California, and also letters from boys in England, France, Japan, Australia, Cuba, South America, and once in a while from some boy who lives in a foreign land of which I have never heard before. Then I have to get out my old geography and study the map to find out where my boy friend lives. I have asked some men whom I know you are interested in to write articles for this book, and besides I have tried to tell you about Gilbert Toys, but before I do let me tell you something about myself, for I have had an interesting life, I can tell you.

I lived away up in the northern part of Idaho, and after I had finished my public school course, my father sent me to Pacific University at Forest Grove, Oregon, and it was there that I became interested in athletics. I did a great deal of wrestling, and one day the school entered me in the Northwest wrestling championship bouts. The first year, although I didn't win, I did very well. I went back home and trained all the harder, believing that if I persistently kept at it, I would some day win the championship. I didn't have to wait very long, for the next year the school entered me again and I succeeded in winning the Pacific Coast championship.

The same year I broke the Northwest record for pole vaulting, and was made Captain of the University Track Team. Although the school had only 150 men in it, I built up a very fine team and organized a training table just like they do at the big colleges. At this time I had no idea that some day I would go to a university like Yale. Although this was a small school, we competed with all the big colleges, and won the track championship of the Northwest. During my three years at Pacific University I took part in a great many contests and won lots of medals and prizes. I then became ambitious to go to Yale, and in 1904 I came to New Haven.

While at Yale I won the "Y" for three different branches of athletics and was presented with 160 different gold and silver medals. I also won the Wrestling Championship of the United States. In fact I was never thrown in wrestling. I was intercollegiate gymnast and won the "Y" for being the best all-round gymnast at Yale. I believe I had more success in Pole Vaulting than anything, for twice I had the world's record, having jumped over 13 feet. I was picked

## MR. GILBERT'S LETTER TO YOU

out to represent America at the Olympic Games in London. During the last few days of the games I was awarded a medal by Queen Alexandria, in the presence of King Edward, as World's Champion in Pole Vaulting.

My main object in telling you this story about myself is to show you that it is the persistency with which you keep after things that counts most in making a success. I feel that every boy should be trained for leadership. It is only the bright-eyed, red-blooded boy who has learned things, done things, dared things beyond the reach of most boys who will find the way open to really big achievements. You see, boys, it is not so very long ago that I was a boy myself, and I know what boys want and the kind of toys they like. That is why, when I started to make Gilbert Toys, I made them genuine.

My toys are toys for the live-wire boy, who likes lots of fun and at the same time wants to do some of the big engineering things—things that are real—things that are genuine. Every toy I make is fully guaranteed to do just what I say it will, or I will give you your money back.

When you are in New Haven, don't forget to come and see me, and I will show you just how Gilbert Toys are made. Read through this book carefully, and don't miss the page on which I tell you about the Gilbert Engineering Institute for Boys.

Sincerely yours,

*A.C. Gilbert*  
President

**THE A. C. GILBERT COMPANY**  
NEW HAVEN, CONN.

New York Chicago San Francisco Toronto London

## The History of Gilbert Toys



Today when I look over our plant covering many acres of floor space, and catch sight of a thousand or more employees, it seems a long time since I first started making Gilbert Toys, but, reckoned in years, it is hardly any time at all. But "much water passes over the dam in a few years." Little did I think those last few years I was in college that no sooner would I graduate when I would be striking out for myself.

Three things always interested me—Athletics, Sleight-of-Hand, and Scientific Experiments. Outside of my school work athletics claimed the major part of my time, but a good share was left to learn the secrets of magic and scientific things, the two hobbies I had ever since I was a boy. Both have been of great service to me: first, to help me earn my way through college and second, to bring science down to a boy's understanding through the scientific toys of our manufacture. The first money I ever made was

by giving magic entertainments to private audiences, and while entertaining one of these audiences in this way, the thought occurred to me that if these same magic tricks I was doing could be put up so that boys would understand them easily, they would have a splendid sale. I determined to try it out. So even before I left college I had rented a small wooden building out in Westville, Connecticut, a suburb of New Haven, and started to manufacture magical apparatus on a small scale. I was my own manufacturer, shipper, and salesman, and during the holiday season I spent a great deal of time demonstrating in some of the larger cities. It was not long before Mysto Magic Sets, as they were called, were known pretty familiarly all over the country.

Manufacturing and selling just magic toys of this kind and type did not satisfy me. I had always felt that toys, besides giving a great amount of fun and enjoyment, also had a big influence on the character of a boy and that they should be considered of greater importance by parents. I realized that as a boy I always had a longing to know more about the secrets of nature and to experiment along scientific lines. So I conceived the idea of manufacturing toys of a character and kind that had been such a hobby with me as a boy—real engineering toys.

I then constructed the first models of what was to become one of the world's greatest toys—ERECTOR. These first models were crude, hand-made things that I spent many an hour working over myself. Finally the dies were completed and we started to produce the first Erector Sets. From that



## GILBERT BOY ENGINEERING



day to this, Erector has been steadily growing in popularity, until it is now sold in almost every country in the world. From the very beginning boys liked it because it was something entirely different from any toy that had ever been given them—its girders were like actual, structural steel, and at that time it was the only toy operated by an electric motor.

Parents were quick to see its educational value and how their boys would benefit by playing with such a toy. While educational, at the same time it was not "school booky," and the hit it made with boys proved its value as a scientific toy.

Its phenomenal success made necessary our moving into a larger plant on Foote Street, New Haven, in 1913, and its continued growth forced us to build our new plant on Fox Street, New Haven, in the early part of 1915.

My experience with Erector showed me I was on the right track. Toys could be made more than mere playthings—they could be made to mean something to the boy and his parents, and so I have continued to bring out many engineering toys of the kind and character that will hold the boy's interest because they are full of intensely interesting things and provide a great amount of fun and amusement.

As you go through this book of mine you will see illustrated the big family of Gilbert Toys that have grown up with this great, big business of ours, until it became necessary to build what they tell me is the largest toy factory in the world, covering many acres. It can be seen standing out conspicuously with its big Wireless Tower on the main New York, New Haven and Hartford Railway going through New Haven. Its front door is always open to any of my boy friends who visit New Haven, to see the wonders of automatic machinery of every description—the kind that are turning out this great family of Gilbert Toys.

*A.C. Gilbert*  
President.

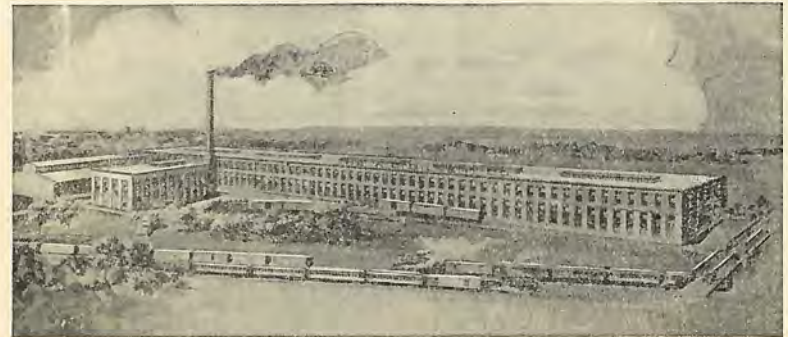

## HOW TO HIGH JUMP

ATHLETIC TRAINER, YALE UNIVERSITY.

By Johnny Mack

Probably the first opinion that everybody gets regarding high jumping is that it requires an extraordinary amount of natural spring and ability, and to a certain extent this is more or less true, because the man with natural spring and other qualifications will probably make a greater high jumper. But at the same time an athlete with ordinary spring and good form can become a good high jumper if he has the persistency and determination necessary.

By persistency and determination I mean sticking to the thing constantly for a number of years until he has mastered it thoroughly.

Form is everything in high jumping. There are a few natural high jumpers who do not master any particular form and depend absolutely upon their natural agility for leaping over the bar, but none of these men have ever become champion high jumpers. World's champion high jumpers are men who have had great patience and determination to learn the correct way to high jump and have taken advantage of all the years of experience that professional training can give in working out an ideal form. The form that we are going to recommend for you to learn is the form that has been used by most of the best known and most successful high jumping athletes.



Johnny Mack, Athletic Trainer, Yale University.  
Richard Langdon, World's Champion High Jumper, 1921,  
setting record at Olympic Games of 6 ft. 3 in.



Fig. 1

kind of special calisthenic work consists in kicking, first one foot and then the other. The natural tendency for a person who kicks is to extend the toes, but in practicing these calisthenic exercises, hold the hand well above the head and try to kick it with the right foot, then with the left, but keep your toes flexed. Later on you will understand this when we describe the method. You should do this every night and morning until your legs become flexible. Very good exercise is walking and bag punching, as that develops the chest, arms and back muscles.

### TRAINING

Persistent training is essential to high jumping or any form of athletics requiring skill and agility.

In learning to high jump a beginner should practice at low heights. In addition to calisthenic work which is going to materially assist you in limbering up and increasing your spring in the start you should practice jumping at low heights every other day until the form is mastered.



Fig. 2

### CALISTHENIC WORK

In the very beginning it is quite important to practice a little each day on certain kinds of calisthenic work that will greatly assist you in developing your form and make of yourself a good high jumper. This



Fig. 3

After you have mastered the form you are then ready for competition, and at this stage you must not jump more than two or three times a week or you will find that you are losing your spring, or to use the athletic expression your "pep", and you will be sluggish, and unable to put your

best into it. A good high jumper must be right on his nerve, so that he can use every available bit of energy possible to accomplish the best results on the day of competition. The day before and the day of competition, the man should rest well and keep off his feet all he can.

Below is an ideal schedule for high jumpers who have succeeded in learning the form:

### RUNNING HIGH JUMP

The height of the bar at starting at each successive elevation shall be determined by the field judges. Three tries shall be allowed at each height. Each competitor shall make one attempt in the order of his name on the programme; then those who have failed (if any) shall



Fig. 4



Fig. 5

have a second trial in regular order, and those failing on this trial shall take their final trial. A competitor may omit his trials at any height, but if he fail at the next height he shall not be allowed to go back and try the height he omitted. Each competitor shall be credited with the best of all his jumps or vaults.

### HIGH JUMP

A line shall be drawn three feet in front of the bar and parallel therewith, such line to be known as the balk line. Stepping over this line in any attempt shall be counted as a balk. Three balks shall count as a try.

Displacing the bar shall count as a try.

### EQUIPMENT FOR HIGH JUMPING

Track suit, consisting of jersey and running trousers, a pair of regular jumping shoes with spikes in the heels and small rubber pad inside to protect the heels from injury and stone bruises.



Fig. 7



Fig. 6

### PIT

It is very important to have a good pit to land in; the best pits are made from a mixture of loam and sawdust, about equal parts and should be raked after every jump. The size of the pit should be nine feet square.

Be sure to keep warm when in competition, always sitting on a bench, keeping your legs warm by wearing flannel trousers and robe; before your turn to jump, warm up well

by jogging and kicking; always begin easy; when ready to jump concentrate your mind as well as your strength on the effort. Have confidence in your ability as that is very essential.

### THE IDEAL HIGH JUMPING FORM

High jumping may be divided into different phases each of which is equally important. The first is the Run, and this is a very important part of the high jump.

#### THE RUN

A long, bounding stride is best for it seems to help you gather up strength for the final effort.



Fig. 8

The important parts of the run are:

To run practically straight down the path to the bar, until the last two strides, then turn at a slight angle — turning on the last stride is bad. (See Figs. 1 and 2; note the way he is coming in). Come in on the flat of the foot, according to the speed a man can carry. Too slow

a run is just as bad as too fast.

A mark should be made about 55 feet back which will bring the jumper to a position for the take off. In addition to this starting mark, another mark about the center of the run will enable him to check up his stride, to insure himself that he is going to assume the right position at the right spot. This also



Fig. 9



Fig. 10



Fig. 11

the ground very hard with the heel. This is called the "take off." (See Fig. 3.)

The right position is where you can get as close to the bar as possible without kicking it off. (See Fig. 4). It is impossible to estimate a definite mark for the "take off," that is the exact number of inches to the bar, as it depends



Fig. 12

insures him of coming in at the right number of strides. A great many runners make the mistake of not making a mark and as a result they never take off at the same place, or they make a good many balks. If the run is right and the mark is right you will have no further difficulty. The first thing is to get the mark located at the right spot because without this you will do a lot of unnecessary running that will tire you out.

When you get a wrong run that brings you too close to the bar you will hit the bar going up and if you are too far back you will reach your height too soon.

In taking the last stride the jumper must hit the ground very hard with the heel. This is called the "take off." (See Fig. 3.)

The right position is where you can get as close to the bar as possible without kicking it off. (See Fig. 4). It is impossible to estimate a definite mark for the "take off," that is the exact number of inches to the bar, as it depends upon the man. A short man can get closer to the bar than a long legged man.

The last stride is just a little longer than the others, keeping the weight of the body over the foot. If too long a stride is taken it will be impossible to do this. Therefore the importance of taking a stride just a trifle longer on the last should be kept in mind.



Fig. 13

For convenience in describing the form we have called the back leg the "kicking leg" and the front leg, that is the one that you "take off" with, the "jumping leg."

Now, as you take this last stride, with the body well over the "jumping leg" kick as hard as you can, with the "kicking leg". (See Figs. 5 and 6).

Note how high the kicking leg is before he leaves the ground. When kicking the leg up do not extend the toes. Keep them in. Note the arms in the air moving up with legs when kicking off the ground. (See Fig. 7). Still on the ground. The kicking leg is at its highest point now and it has done its work. The jumper now springs off the ground and using his jumping leg he repeats the kicking with the jumping leg as high as he possibly can until he reaches his height.



Fig. 14

Carefully note each one of the photographs, (Figs. 8, 9, 10 and 11) where the height of the kick has been reached. The jumper has put all his force into it. Very few high jumpers realize the importance of the kick with the jumping leg. (Figs. 8, 9, 10 and 11) represent the different positions while he is putting everything into this kick. Fig. 11 represents the high point of the jumping leg; it is the danger zone.



Fig. 15

Now the next thing is to get across the bar, and this is accomplished by the use of the jumping leg and the arms. Carefully note the left leg because the problem in front of the jumper now is to get himself across the bar. After he has reached his height it is absolutely essential that the jumping or left leg is powerfully driven horizontally across the bar. At the same time carefully note how the jumper uses his arms. The right arm is

swung over throwing the jumper into the position of facing the bar. The left arm will help a lot and is very important in assisting the body to face the bar and carry it across the bar past the danger zone.

Note carefully illustrations 12, 13 and 14 which beautifully illustrate the use of the arms and the driving of the legs in making this turn and carrying the jumper across the bar.

### THE LANDING

Note that he still keeps his right leg in the air. Be sure and land on the jumping leg and also note how the arms are thrown backward to be sure of not pulling the bar with the hands. (See Fig. 15).



## MEN AND EVENTS IN THE HISTORY OF 1920 SPORTS

The year of 1920 was a great one in the history of sports and it will stand out conspicuously as the world's greatest achievements in sports to date. I say this because:

**First.**—The great International Yacht Race was held and won by the American Yacht **Resolute**.

**Second.**—The world's championship in Tennis was won by Tilden and Johnston of America and the Davis Cup was regained.

**Third.**—**Man O'War**, the greatest race horse that ever lived swept the American tracks, winning over Sir Barton of Canada and so held the championship honors for the United States.

**Fourth.**—The world famous Olympic Games that are held every four years took place and America again triumphed, and,

**Fifth.**—Lasker, the chess champion of the world, gave the title to Capablanca, the great Cuban chess player, and these two masters are at this writing, playing a close game for the world's championship. Samuel Ryeschewski, the champion boy chess player startled the world by his wonderful playing. All of the above events will be described in detail below.

**Record of Sports in General.**—It is far too long a story to give all the sporting records that were made in 1920, but the list of leading champions and championship events which follow shows those who and which were accounted best.

(1) **All Round Athlete.**—Brutus Hamilton, of the University of Wisconsin, was adjudged the champion all round athlete of the United States.

(2) **Automobiling Racing.**—Gaston Chevrolet, since killed, was the leading motor car driver. In the Speedway Race at the Indianapolis track he drove a Monroe car 500 miles in 5 hours, 38 minutes and 32 seconds.

(3) **Aviation.**—At Dayton, Ohio, Major R. S. Schroeder, U.S.A. made a new altitude record when he piloted a **LaPere** biplane to a height of 36,030 feet, which is nearly seven miles. The temperature at this height is 67 degrees below 0.

At Etamps, France, Lieutenants Bossoutrol and Bernhard drove a **Farnham-Soliath** plane in a non-stop flight for 24 hours, 19 minutes and 7 seconds, thus breaking the world's endurance record. At San Antonio, Texas, Lieutenant John H. Wilson made a parachute jump from an airplane when at a height of 19,800 feet and landed nearly 10 miles from where he left the airplane and so made a new world's parachute record.

At Mineola, Long Island, Captain C. C. Mosley, U.S.A., broke the world's speed record with a **Verville** plane when he averaged 178 miles an hour. He was awarded the **Pulitzer Trophy**, a classic figure holding up an airplane, and \$1500 in Liberty Bonds. Over 40 other airplanes competed for the prizes and 28 finished the full 132 mile course.

(4) **Baseball.**—The **National League** baseball pennant was won by the Brooklyn team and the **American League** pennant was won by the Cleveland team. The **World Series** played by these two teams was won by Cleveland who beat Brooklyn five out of seven games.

Ty Cobb is the greatest all round baseball player. He has led the American League for batting twelve times during the last fourteen years. And he has led time and again in base-stealing. He is the fastest player in baseball and is the manager of the Detroit Team.

"Babe" Ruth of the **New York American League** team made 54 home runs which was a new home run record. Of his 54 baggers 37 were delivered by right handed pitchers and 17 came from **southpaws**. Of his homers 29 were made at the Polo Grounds, N. Y., and the rest of them were made when he was on the road.

(5) **Basket Ball.**—The **Amateur Athletic Union** championship games were played at Atlanta, Ga., and there were 16 colleges and clubs entered. The **New York University** team defeated the **Kansas City** team 45 to 22, while the **Rutgers College** team won from the **Detroit** team 35 to 17. In the final game **New York University** defeated Rutgers 49 to 24.

(6) **Bicycling.**—Fred Taylor, of the New York Athletic Club, won the National Amateur bike sprint title at Newark, N. J., with 20 points. Maurice Brocco and William Coburn won the 6 day bicycle race at Madison Square Garden, N. Y.

(7) **Billiards.**—The amateur billiard tournament, **Class A**, was won by Percy Collins, of Chicago; **Class B** by Julian Rice, N. Y.; **Class C** by Sidney Russell, Brooklyn, and **pocket billiards** was won by Howard Shoemaker, N. Y. The **18.1, 18.2** balkline billiard tournament was won by Willie Hoppe, of New York. The 3-cushion carous by John Dayton, Sedalia, Mo., and **pocket billiards** by Ralph Greenleaf, Wilmington, Del.

Willie Hoppe is the greatest billiard wizard in the world. He began playing when he was only 7 years old and had to stand on a soap box to make the shots. His success is due not only to his natural ability but to his steady nerves and everlasting perseverance. While yet a boy he found that alcoholic drinks and tobacco were bad for his nerves so he never used them. He never swears and no one has ever seen him lose his temper. When he is playing a championship game he loses himself completely in the three ivory balls on the green table. He would have succeeded in any line of business equally as well, and if you cultivate his habits and qualities you can too.

(8) **Boxing.**—Jack Dempsey, U.S.A. is the professional **heavyweight** champion of the world; Georges Carpentier, France, **light middleweight**; Johnny Wilson, Boston, **middleweight**; Jack Button, N. Y., **welterweight**; Benny Leonard, N. Y., **lightweight**; Johnny Kilbane, Cleveland, Ohio, **featherweight**; Joe Lynch, N. Y., **bantamweight**; and Jimmy Wilde, Wales, **flyweight**.

(9) **Canoeing.**—Leo Friede of N. Y., won at Clayton, N. Y., the National canoe sailing title making 6 miles in 1 hour, 5 minutes and 3 seconds.

(10) **Chess.**—The chess champion of the world is J. R. Capablanca, of Havana, Cuba. The title was given to him by Dr. E. Lasker, of Berlin, who held the championship for a quarter of a century. Much interest in chess circles was aroused in this country by the appearance of Samuel Ryeschewski, the 11 year old boy champion of Poland. Out of his first three public exhibitions when he played a total of 60 games, he won 51, 7 were draws and he lost 2 games.

(11) **Cross Country Running.**—Fred Fuller, of Boston, was the **senior individual** champion, and W. Ritola, of N. Y. was the **junior individual** champion in the cross country run of the **National Amateur Association Union**. Cornell won the **International**.

(12) **Fencing.**—In the final round of the **National Team** championship the **New York Athletic Club** versus the **Washington Army Fencer's Club**, the former won 5 bouts and the latter won 1.

(13) **Football.**—The popularity of intercollegiate football continued to increase last season and the attendance and gate receipts in all parts of the country broke all previous records. The **Princeton University** football team won the championship according to popular opinion.

(14) **Golf.**—The past season was the most eventful one in this sport for American golf champions went to England and to France to take part and Britishers came over here to compete for the **open** and **amateur** championships. On this side of the pond the open championship was won by Ed. Ray, of England, at Inverness, Toledo, Ohio, while the amateur championship was won by Charles (Chick) Evans, of Edgewater, Ill., who defeated Francis Onimet, of Woodland, Mass., at Engineers, Roslyn, Long Island, by 7 to 6.

(15) **Gymnastics.**—The National all-round gymnastic title of the United States was won by Joseph Oszy, of the N. Y. Athletic Club in the **National Amateur Association Union** events at New York.

(16) **Lawn Tennis.**—William T. Tilden, 2nd, won the United States championship event at Forest Hills, N. Y., when he defeated W. M. Johnston, of San Francisco. Tilden also won the world's championship at Wimbledon, England. With Johnston he won the Davis Cup for America, taking it away from Australia.

Imagine a little, skinny fellow who weighs 120 pounds, a bundle of nervous energy who drives a fast and furious ball and you will have a mental picture of Johnston. If you could see him in action you would know that however small a fellow is he has just as good a chance in athletics as the big fellow. Now take a look at Tilden; he is a tall, lanky fellow, whose movements are well timed and he always has himself well in hand.

The wonderful work of Tilden and Johnston show what years of patience, practice and perseverance will do. They have played tennis ever since they were boys and they won out because they never lost their courage. So when you go into athletics or anything else do so with the firm determination that you are going to succeed and you will.

(17) **Court Tennis.**—The National professional championship was won by Walter Kinsella, and the National amateur championship by Jay Gould.

(18) **Racquets.**—The World's professional title was won by Jack Soutar, of New York and the National amateur championship by Clarence C. Pell, of Tuxedo, N. Y.

(19) **Motor Boating.**—The International races for the world's championship as typified by the Harmsworth motor boat trophy, took place at Cowes, Isle of Wight, England. The United States motor boat **Miss**

**America**, won both races. She also won the 1 mile championship trophy on Lake George, showing an average speed of 76.73 miles per hour. On one trial she made 77.85 miles per hour.

(20) **Racing.**—Last season was the greatest in many ways in the history of the turf. **Man o'War**, the greatest horse of any age won 11 races and did not lose a race. He was proclaimed the champion by beating **Sir Barton** who had held the championship before him. The leading jockey of the year was Jimmy Butwell who rode **Man O'War** to victory.

(21) **Rowing.**—The National amateur championship single was won by J. B. Kelly in 7 minutes and 51 seconds at the National regatta held at Worcester, Mass. The International professional championship was won by Ernest Barry of England.

(22) **Shooting.**—The American amateur championship at single targets was won by F. S. Wright of Buffalo, N. Y. The professional championship at singles was won by C. S. Spencer, of St. Louis, Mo.

(23) **Wrestling.**—The champion professional wrestler is Ed. (Strangler) Lewis, of Kentucky, and the **National Amateur Association Union** heavyweight champion is Mat Pendleton, of New York.

(24) **Swimming.**—The champion swimmer is Norman Ross, of Brooklyn, N. Y.

(25) **Yachting.**—The history of the **America's Cup** is this: In 1851 the **Royal Yacht Club**, of England, offered to the winner of a yacht race to be sailed round the Isle of Wight, a course of 60 miles, a silver championship cup. The race was won by the yacht **America** and the cup became known as the America's Cup.

Shannon IV from Sir Thomas Lipton of Great Britain, was especially built for this race.

This was the fourth attempt of Sir Thomas to take the America's Cup back home but as yet he has not succeeded. His great good humor, and his exceeding firmness has made him beloved by all American sportsmen. He has too always stood for clean athletics.

One of the America's opponents was the British schooner **Aurora** which came in second. The time of the **America** was 10 hours and 34 minutes, and the **Aurora** came in nearly half an hour later. The America's Cup has been defended 13 times during the 68 years that it has been in this country. The last race was in July of 1920 when the American yacht **Resolute** won three out of five races off Sandy Hook, N. Y., by 19 minutes and 45 seconds.

**The Olympic Games.**—The seventh revival of the **Olympic Games** was held in Belgium during the spring and summer of last year. There were more than 30 different kinds of sports represented and the contests opened in April and did not close until September. Five new world's records were made and of these the team for the United States secured three so that it easily won first place. At the close it had 212 points to its credit, the second place being won by Finland with 105 points. In other words the United States has the greatest athletes in the world.

## WORLD'S FAMOUS ENGINEERING ACHIEVEMENTS

There are some men who can see further ahead than others. They are inventors and engineers and those who became famous for their works have constructive brains, sharp eyes and hands that know how to use tools. The instant they see a machine running or an operation in progress they sift out its weak points and know how it could be improved.

It is to men of this caliber to whom the world owes its scientific and industrial development for they either seize on the old and make it work, or do its work better, or quicker or cheaper, or all of these at one and the same time, or else a new idea burns in their brains and they work it patiently out as Morse did the telegraph, Bell the telephone and Edison the phonograph.

And if you will read the lives of the men who have made notable additions to science, and especially to that great useful branch of it which we call engineering, you will find that all of them liked to and did use tools, when they were boys, and put together and built things that surprised their elders. This early work which they did in the spirit of pure pleasure was of the greatest service to them when they grew to manhood as for instance Watt, Stephenson and Fulton each of whom made every detail of their own models.

Hundreds of other men have had just as new and novel ideas but they failed in their execution. For while they could picture their improvements in their minds eye they could not for the life of them shape them in the concrete form because they did not know how to use tools. My advice, therefore, is to start now to do and to make things with tools. Why, way back there when Sir Isaac Newton was a boy, and tools and materials were scarce, he developed a great talent for inventing and making mechanical devices. Sir Davy Brewster who wrote a story of his life says:



SIR ISAAC NEWTON

"He had not long been at school before he exhibited a taste for mechanical inventions. With the aid of little saws, hammers, and tools of all sorts he was constantly occupied during his play hours in the construction of models of known machines and amusing contrivances.

"The most important pieces of mechanism which he thus constructed were a windmill, a water clock and a carriage to be moved by the person who sat in it. When a windmill was in the course of being erected near Grantham, Sir Isaac frequently watched the operations of the workmen and acquired such a thorough knowledge of its mechanism that he completed a working model of it which was as clean and curious a piece of workmanship as the original.

"This model was frequently placed on top of the house in which he lived and was put in motion by the action of the wind upon its sails. In calm weather, however, another mechanical agent was required and for this purpose a mouse was put in requisition which went by the name of **mill**.

"The water clock constructed by Sir Isaac was a more useful piece of mechanism than his windmill. It was made of wood and resembled pretty much our common clocks and clock cases, but was less in size, being about 4 feet in height and of a proportionate breadth. There was a dial plate at the top with figures of the hours. The index was turned by a piece of wood which either fell or rose by water dropping.

"The mechanical carriage which Sir Isaac invented was a four-wheeled vehicle and was moved by a handle, or wince, by the person who sat in it. Newton also introduced the flying of paper kites and constructed also lanterns of crumpled paper, in which he placed a candle to light him to school in the dark winter mornings, and in the dark nights he tied them to the tails of his kites, in order to terrify the country people who took them for comets. Finally, when a young man, he made a telescope with his own hands."

What Sir Davy said of Newton's inventiveness applies to all the great inventors and engineers as the following outlines clearly show.

### WATT AND THE STEAM ENGINE

The first of the great modern engineering feats was the invention of the steam engine. It was James Watt who made the slow, inefficient steam engine of Newcomen the great prime mover as we know it today.

When quite a small boy Watt's father gave him some carpenter's tools. With these the youngster showed much skill and ingenuity making over his old toys and inventing new ones. In those days of hard workers people thought Watt was an idler but, while common labor did not appeal to him, his mind was hard at work trying to solve the mysterious power of steam.

**A Natural Philosophy\*** came into his hands when he was fifteen and he read it through twice with diligence and care. About this time he also made many chemical experiments and did them, not once, but many times so that he could be sure he had made no mistake. Another of his boyhood achievements was an electrical machine which he made with his own hands and very often he would get a crowd of boys together and give them some good "shocks".

\*Such a book is now called a **Physics**.

So skillful was he with tools that he went to London and learned the trade of instrument maker. After he had worked a year there he went to Glasgow and set up a shop of his own. Trades in those days were very jealously guarded and he would not have been able to make a living had he not been appointed instrument maker to the university there.

To add to his income he did surveying and it was while at this work that he thought out the most important improvements he intended to make in the steam engine. As the cylinder of the Newcomen engine also acted as the condenser the piston moved very slowly so Watt devised a condenser that was separate from the cylinder and this made it possible for it to work faster. He also applied the flywheel to the engine so that its reciprocating motion was changed into rotary motion, and, finally he invented the governor for regulating its speed. Besides these great improvements he made many smaller inventions. He had a wonderful memory and he read everything that had a bearing on science and engineering.

### STEPHENSON AND THE LOCOMOTIVE

George Stephenson was the first to apply the locomotive engine to railways for passenger service and his famous **Rocket** fixed the design of steam locomotives for all time.

As a boy Stephenson worked in a colliery, as a coal mine is called, and he was promoted to assistant fireman, fireman, brakesman and finally, to engineer. A few years later he and two others were hired to run the engines at the Killingworth pit and later, due to his knowledge of engines and skill as a machinist, he was made **engine wright**, which is the same as a master mechanic today.

The idea of using the steam engine to haul the tramcars, instead of horses, was uppermost in the minds of the collier owners and Stephenson, backed by Lord Ravensworth who knew of his ability as a designer and mechanic, worked out the plans for a small locomotive and built it. It successfully hauled light loads at a speed of about four miles an hour.

To make the boiler keep up steam better Stephenson invented the **air-blast**, so that the used steam exhausted through the smoke stack and thus pulled a blast of air through the fire box. This improvement doubled the speed of the locomotive. Then came a competition in which the best locomotive was to be used on the line between Liverpool and Manchester.

Stephenson built his **Rocket** in which the piston was directly connected to the drive wheels. It was the most successful of those it competed against and ran away from them. It was chosen to carry both passengers and freight on the new railway line and so the steam locomotive that had been a dream so long was now an actual fact due to the genius of Stephenson.

George Stephenson had one son whose name was Robert and he became a great bridge builder. He was also a thorough mechanic and worked with his father when the latter was building the **Rocket**. Later Robert became the engineer who built the **London and Birmingham Railway**, the first railway to run into London.

### FULTON AND THE STEAMBOAT

The invention of the steamboat by Robert Fulton is one of the most wonderful and gripping stories to be found in the history of men who did things. Like the steam engine of Watt and the locomotive of Stephenson his steamboat of Fulton was not an absolutely new invention but like the others Fulton was the man who put it across the dividing line of experiment and made it a practical success.

Like nearly all boys who had genius Fulton's family were poor but as he showed much talent for drawing he was able to raise sufficient funds to go to England at the age of twenty-one to study painting there under the great American artist, Benjamin West. But scarcely had he reached England than his mind turned to invention and engineering and one of his first jobs was to help the Duke of Bridgewater to build a canal and to devise the locks for it.

He next invented a rope making machine and a mill for sawing marble but his chief concern was to apply steam to the propulsion of boats and he stuck to this project for nearly fifteen years although he encountered the greatest of obstacles. Having finally perfected plans he returned to America and built the steamboat **Clermont**. It was



ROBERT FULTON

a memorable day in history when she was ready for the trial trip.

The time set for her departure was an August morning in 1807. Passengers had been booked from New York City to Albany and they were in the boat while a great crowd lined the shore to see what they should see. The **Clermont's** boiler had been fired up and all was in readiness.

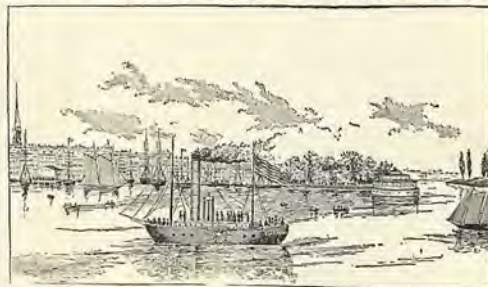

The Departure of the "Clermont" on her First Voyage

A blast from the whistle served notice that she was ready to go, her engines were started and the first practical steamboat ever built moved slowly off and up the river under her own power.

She reached Albany in due time and the inventor of the **Clermont** and her passengers landed without mishap. Fulton's belief in himself and in steam navigation had at last been justified and from that humble beginning has grown the great fleet of steamships that now sail the rivers, lakes and seven seas of the earth.

### WHITNEY AND THE COTTON GIN

Of course you have heard of Eli Whitney and know that he was the inventor of the cotton gin. He was born **down East**, that is to say in New England, a few years before the Revolutionary War. Now even in those early days a shop with tools of various sorts in it was a necessary adjunct to every farm and when the weather was such that work could not be done outside the farmer and his sons made new things and mended old ones.

It was in this way that Whitney while a small boy learned to use tools and he very early showed a tremendous interest in machinery. He was forever wanting to know what made the wheels go round, and in one instance to find out he took his father's big silver watch apart while his father's big silver watch apart while the old gentleman was unconscious of



ELI WHITNEY

the fact, at a Sunday meeting. Let it be said to young Whitney's credit, and fortunately too for him, that he was able to get all the wheels back and the watch to ticking merrily again before his father got back home. He was then only ten years old.

When he was twelve he made a fiddle that was considered a very good instrument. While he was yet a boy and the Revolutionary War had cut off the trade between England and this country nails became a very scarce article so Whitney got busy and hammered them out by the score thereby putting some money in his pocket.

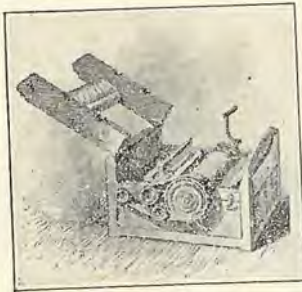

The Cotton-Gin

His invention of the cotton gin which separated the cotton from the seed was his crowning achievement though he never made money out of it for he had to constantly fight off infringers and the legal battles that were waged impoverished him. Being an expert mechanic he finally got a contract to make firearms for the government and out of which he made a future.

### MORSE AND THE TELEGRAPH

The father of Samuel Finley Breeze Morse was a minister and the son was not of the mechanic type. But he had far seeing vision and he must have been a good student for he was admitted to Yale college when he was fourteen.

While there he became especially interested in the experiments in chemistry and natural philosophy and from the latter Morse learned about electricity and magnetism. One of the famous experiments of the time and for a good many years after was for the professor to have the students join hands and give them a shock.

While Morse was interested in the experiments he had long before decided to become an artist for he had great talent and partly paid his way through college by painting miniatures. On graduating from Yale he went to Europe to study art and lived



SAMUEL F. B. MORSE

abroad for twenty years. Having become famous as a portrait painter during this time he set sail for his native land on the good ship **Sully**.

During the long voyage the conversation turned to many subjects. That of electricity came up and one of the passengers said he had heard that electricity will travel over a long wire almost instantly. Morse replied if that was true intelligence could be transmitted by it to any distance. He spent the remainder of the trip in working out his electromagnetic telegraph on paper of which his relay, printing register and code of dots and dashes were the chief parts.

As the apparatus was original Morse could not buy it and he had no money with which

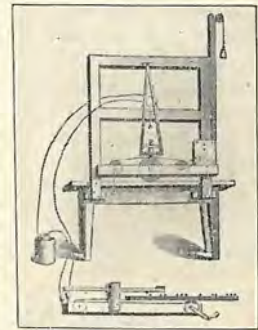

Morse's First Telegraph

to hire it made. As a boy he had learned a little about tools and so he set to work and built the instruments himself. After many disappointments, hardships and ridicule Congress finally appropriated \$25,000 so that Morse could put up a line between Washington and Baltimore. On May 24, 1844 the telegraph line was finished, the first message was sent and Morse's victory was complete.

### BELL AND THE TELEPHONE

Like Morse, Alexander Graham Bell the inventor of the telephone was not a mechanic but he was a far seeing investigator in the realm of physics and he was particularly interested in that branch of it that has to do with sound. That he had ability must be admitted for he was able to get a position teaching elocution when he was only sixteen.

When he was twenty-one a friend who had translated Helmholtz's great book on the **Sensations of Tone** showed Bell how the German scientist kept tuning forks vibrating continuously by means of electro-magnets and by making several of them vibrate at the same time sounds were set up that were very like the human voice. Bell's imagination immediately formulated the idea of sending musical notes over a wire by electro-magnetism, and this he called a **musical telegraph**.

Sailing from England soon after, he made his home in Boston and by means of visible speech he was very successful in teaching deaf mutes to talk. He made tracings of the human voice on smoked glass and found how sound waves affect the ear drum and bones of the ear. This led him to conceive that by placing two thin disks of iron close to two electro-magnets and connecting the latter by means of a wire circuit he ought to be able to transmit and reproduce speech; that is when sound waves struck the disk of one instrument it would set up currents in the electro-magnet, these would be transmitted along the line where they would affect the other electro-magnet, and which in turn would make the iron disk vibrate like the first one and so reproduce the words spoken at the other end.

To make an instrument that would perform this wonder was a mighty hard job and at first only grating sounds came forth but by persevering Bell finally succeeded in making a pair of instruments that actually talked and the telephone was invented. The **Centennial Exposition** had just opened and Bell's new telephone was publicly exhibited there for the first time. Emperor Dom Pedro of Brazil was the first to put the receiver to his ear and Bell spoke into the transmitter at the other end of the wire when the Emperor exclaimed, "My God it Talks!"

### HOWE AND THE SEWING MACHINE

It is a curious fact but none the less true that many of our greatest inventors and engineers were brought up not in machine shops, but on

farms and Elias Howe the inventor of the Sewing Machine was one of them.

If you could have seen Howe when he was a boy you would never have guessed that he was to render humanity a great service and win a large fortune for himself for he was undersized, had poor health and was further handicapped by a lame foot.



ELIAS HOWE

was on the right track. He then borrowed \$500 and inside of six months he had completed a machine that would actually sew.

Like nearly every other early inventor he was very poor — so poor that he had to borrow a suit of clothes in which to follow his wife to her grave and after many hardships his sewing machine was finally put on the market where it at once won success. Howe's income was \$200,000 a year when he was only thirty-five and he was worth \$2,000,000 before he was fifty.

### BESSEMER AND CHEAP STEEL

Iron was known to the ancients but it was only two centuries ago that it began to be used extensively. This was because Dud Dudley discovered that iron could be smelted with ordinary coal where up to that time it had been smelted with charcoal.

To convert iron into steel was a laborious and costly process until an easy and cheap way to make it was found by Henry Bessemer in 1855. Bessemer was one of those boys, who are natural born mechanics

and he would a deal rather turn things on a lathe than to play games with the boys.

While he had not much schooling he possessed great inventive ability and was a thorough investigator. Even as a boy he got the idea of adding a little copper to ordinary type metal and this made the type give a sharper impression and to last longer. He engraved rollers that were used for embossing paper and finally, on examining the expensive hand made German bronze powders with a microscope he decided he could make them by machinery at a much lower cost, which he did and won a fortune.

It was while the Crimlan war was being raged that he designed an elongated projectile but he found that the iron cannon then in use was not strong enough to stand up under the strain of firing it. He then tried to find a way to make the iron stronger. At this time he was in Paris and in this work he was encouraged by the Emperor Napoleon. And he did make cast iron that was better than any that had ever been made before, and further improvements led to his making malleable iron and steel.

His great invention that was to make steel in large quantities and nearly as cheap as iron itself consisted of forcing air through melted crude iron. To do this he designed a **converter** which consisted of a huge iron resort lined with fire-clay and hung on trunnions. The molten iron is poured into the retort and a blast of air is forced through it from the bottom and this converts it into steel.

### McCORMICK AND THE REAPER

While Cyrus McCormick is usually credited with the invention of the reaper some writers claim that Obed Hussey invented it in 1833. The truth of the matter is that Hussey invented the iron fingers which keep the grain upright and the reciprocating knife which cuts the stalks.

But from Hussey's mower to a practical farm reaper was a far cry and it was the mechanical genius of McCormick that put it over the line that made it a practical success. Cyrus went to school when he could but like other farmer's boys he had to work most of the time. He was a boy who thought long and hard and when he tackled a job he stuck to it for all he was worth.

When he was only fourteen he wanted a map of the world but not having the wherewithal to buy it he drew one that was surprisingly accurate. One day when he was about fifteen he started out to reap and although he was a mighty worker, like his father he felt that there must be an easier and quicker way to reap than by hand and this thought he kept firmly fixed in his mind. Like many other famous engineers he took up surveying, he was then eighteen, and he made a surveying instrument with his own hands.

The senior McCormack got the idea of making a reaping machine some time before Cyrus was born, but when he built it it would not

work. He spent several years on an improved reaper but the new one likewise failed to work, and so after fifteen years of experimenting and hard work he was forced to give the reaper up as a hopeless job.

When Cyrus was twenty-two he took the crude reaper his father had built and by his mechanical ability and perseverance he developed it into a machine that worked so well the first time he put it to the test that he cut six acres of oats with it.

### EDISON AND HIS INVENTIONS

The boyhood life of the greatest of all inventors, Thomas Alva Edison, is so well known that I will only touch a few of the high spots of it here and his inventions are so well known it will not be necessary to go into details concerning them.

Edison was a born genius if ever there was one. His father was a hard-working man and in poor circumstances. His mother gave him what little education he had and his father taught him the use of tools. He was not a very popular boy among boys for his mind ran to science and invention while theirs ran to fun.

When he was twelve he had to get out and earn his own living and so the first job he got was on the **Grand Trunk Railway** as a train boy. He was so successful selling papers that he believed a paper printed on the train would pay. He got permission to use a part of a smoking car for his printing office and he got enough type from the **Detroit Free Press** to print it with. It was the first newspaper in the world to be printed on a train and, I believe, the only one.

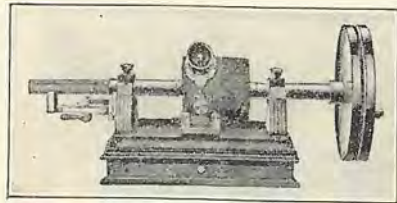

Edison's First Telescope

Then a telegraph operator who liked him, taught him telegraphy and Edison made a miniature telegraph set at a gunsmith's shop in Detroit. It was complete in every detail, worked like a regular set and yet could be placed on an envelope. It took him just three months of his spare time to become a proficient operator. To be able to send and receive messages was all right but Edison was a fellow who wanted to know the **cause why** of things and so he began to experiment with electricity.

He put up a short telegraph line between his house and that of a friend and then he wanted to find out if he could not use frictional electricity to send messages with instead of a current from a battery so he connected up two big, black cats to the line and generated the **juice** by rubbing them. Edison became the fastest operator of his day and there were a good many fast ones.

His first real invention was an **automatic repeater**, an instrument by which two separate telegraph lines could be connected together and thus a message from one could be transferred to the other without the aid of an operator. His next invention was to send two messages at the same time over a single wire and in 1869 he tested the **duplex telegraph** as it was called in actual practice and it worked to perfection.

Following the duplex he invented the **quadruplex telegraph** so that four messages could be sent at the same time over the same wire. After having successfully achieved this wonder he worked out the incandescent lamp and system of lighting, and then followed the simplest and greatest of all his inventions—the phonograph. It was the electric light, though, that made him a rich man. He has taken out more than 900 patents.



THOMAS ALVA EDISON

## THE WRIGHT BROTHERS AND THE AIRPLANE

It was a toy that led the Wright Brothers, Wilbur and Orville, to invent the airplane. It came about this way. Their father was passing a store one day and in the window he saw a little contrivance with a propeller at each end and connected together with a rubber band, a sign on it said it was a **flying machine**.

Though their father was a bishop, he was always greatly interested in mechanics so he bought the toy and took it home to his boys. The boys called it a **bat** and thought it was about the cleverest scheme that had ever been invented for fly it really did. Now the boys were quite skillful with tools and could make anything they liked within reason. Some years after they had played with the **bat** they began to wonder why a real full-sized flying machine had not been built and they began to make another bat only larger.

As they grew into young manhood they began to work with bicycles, repaired and made them and invented a safety brake. Like nearly all other inventors they were poor business men and so just managed to keep things going. At that time, 1898, Lilienthal, a German, was making experiments with his glider in which he was finally killed. His spectacular gliding flights and tragic death recreated a desire on the part of the Wrights to build a real flying machine and from that time on they read everything they could find on the subject and at the same time planned and experimented.



WILBUR WRIGHT

First they built a biplane glider, that is a plane like an airplane but without the engine. This glider they took to the sand-dunes of Kitty Hawk in North Carolina; at first they flew it like a kite and then, in turn, they got into the glider and learned how to balance it in the air. In the fall of 1902 they made nearly a thousand flights, nor did they let the figures of Simon Newcomb, the

great mathematician, who proved conclusively (to his own satisfaction) that no heavier-than-the-air machine could support itself in the air, much less fly, deter them.

Finally they put a gasoline engine in their glider and fitted a pair of propellers to it. Then on the 17th day of December, 1903, Wilbur Wright, took his seat in the airplane, turned on the power and made the first man flight in the history of the world. His flight only lasted 12 seconds but it proved that mechanical flight was possible and that the airplane was a reality. They had made the greatest of all inventions.

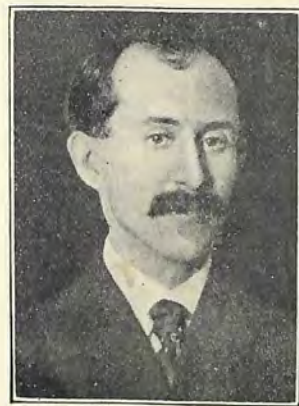

ORVILLE WRIGHT

# HOW TO MAKE WORKING DRAWINGS

By A. Frederick Collins

One of the biggest mistakes that boys make — and many men too — is to try to build a thing out of wood or metal without having drawn a picture of it first.

What is more, the picture should be drawn **to scale** of the object you intend to make, that is, it should be of the exact size, or smaller or larger just as long as it is in proportion to the object you are going to make. Finally you should mark all of the dimensions — that is, the length, breadth and thickness — on the picture and then you can go ahead and do the work without any guessing as you go along.

Such a picture is called a **working drawing** and all you need to make simple plans with is a sheet of **paper**, a **ruler**, a **pencil**, a **rubber eraser**, a pair of **dividers** and a pair of **compasses**. To make accurate working drawings, and this you ought to do, you need in addition to the above tools a **drawing board**, about 12 x 17 inches on the sides, a **30 degree triangle**, 5 or 6 inches long, a **T square** 20 inches long and half a dozen **thumb tacks**.

## What the Tools are for

Of course, you know what the paper, pencil, rubber and rule are for but as the other articles are not so common, I will briefly describe them. The dividers consist of a pair of legs hinged together at one end and whose other ends are pointed as shown in Fig. 1. It is used to space off distances and divide them into parts.

The compasses are like the dividers in that they have a pair of legs, but different from the latter, the free ends are blunt and hollow so that a needle point can be fixed in one and a pencil or a pen point in the other. A pair is shown in Fig. 2. Compasses are used to draw circles and arcs of circles. The drawing board, see A, Fig. 3, has perfectly straight edges and cleats on the sides or bottoms so that it won't warp. The end edges and the side edges are at exact right angles to each other so that the corners are square.

The T Square, B, Fig. 3, is a long thin strip of wood, which is called the **blade**, with a short, thick strip, called the **bead**, fixed to and at right angles with one end of it. To use it the blade is laid on the board with the



Fig. 1



Fig. 2

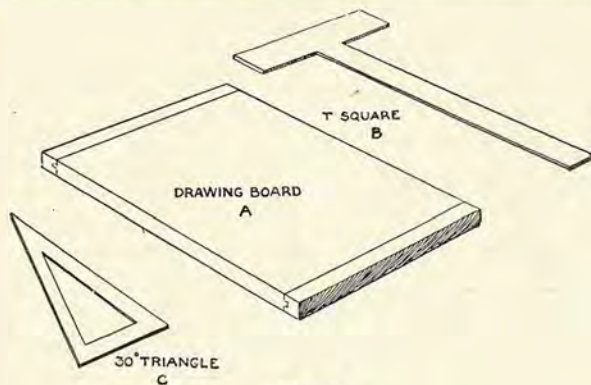

Fig. 3

bead against the left hand edge. Its use enables you to draw one or more perfectly straight horizontal lines on the paper underneath it.

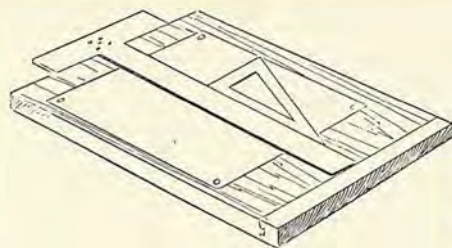

Fig. 4

The triangle is made of thin wood, hard rubber, or celluloid, as is shown at C, Fig. 3. Two of its edges are at right angles to each other and its other and long edge has a slope of **30 degrees**. By laying one of the short edges on the straight edge of the T Square, as shown at Fig. 4, you can draw a perfectly true vertical line or a line having a 30 degree angle, or slant, and the purpose of which I will describe presently.

## How to Make Simple Working Drawings

The first kind of working drawings you should learn to make are called **plans**. These show the different sides, the top and bottom of the object you intend to build, just as though you were looking directly at each from the center.

When you can draw the plans for a box and other simple objects you can then take up **isometric** (pronounced i-so-met'-ric) drawing which shows the object as it will look when completed. From its name you may think it is hard to learn and harder to do but, on the contrary, it is very simple.

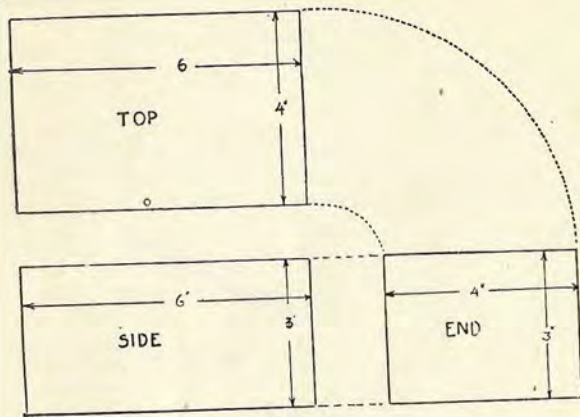

Fig. 5

### How to Make Plan Drawings

The best object to draw the plans for first is a box, because it is the easiest and the moment you get the knack of it you can draw plans for things that are much more complicated.

Now, as you well know, a box has four sides, a top and a bottom. If the box is longer than it is wide the ends will be of the same size, the sides will be of the same size and the top and the bottom will be of the same size, hence, you only need to draw one side, one end and the top as shown in Fig. 7. Of course, you know in your mind how large you want the box to be and so you draw the end, side and top **to scale**. That is, if you want the box 3 inches high, 4 inches wide and 6 inches long you can draw your plans to this size, or you can draw them half, or quarter size when they will still be to scale.

When you have the end, side and top drawn, put in the dimensions which you do by drawing double pointed arrows across the plan views and marking in the measurements, all of which are also shown in Fig. 5. From the plans thus made you can get a pretty good idea of whether the box will look the way you want it to

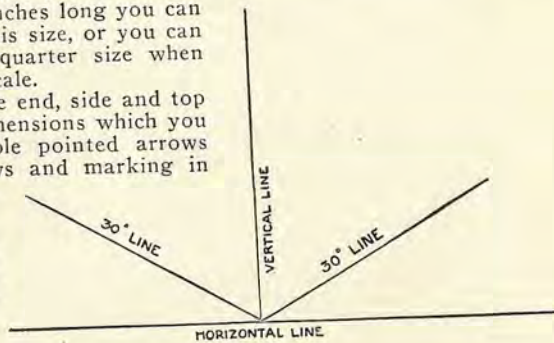

Fig. 6

look when you have made it in wood or metal. Moreover, whatever changes you want to make you can make in the plans much easier than in the object itself.

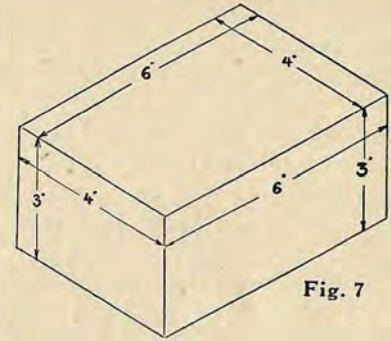

Fig. 7

### How to Make Isometric Perspective Drawings

An isometric drawing gives a perspective view of an object, that is, it makes it stand out in relief, but it is not **true perspective** for there are no **vanishing points**. But an isometric drawing will show you exactly how the object itself will look when it is done and this is a decided advantage over plan views in some cases. As a matter of fact you should make the plan views first and next an isometric picture of it and then when you begin to fashion the object in wood or metal you will know exactly what you are about.

To make an isometric drawing begin by drawing a horizontal line with your T square well down on the paper; then draw a vertical line in the middle of it and two 30 degree lines, one on either side of it, starting at the point where the vertical line intersects the horizontal line, as shown in Fig. 6.

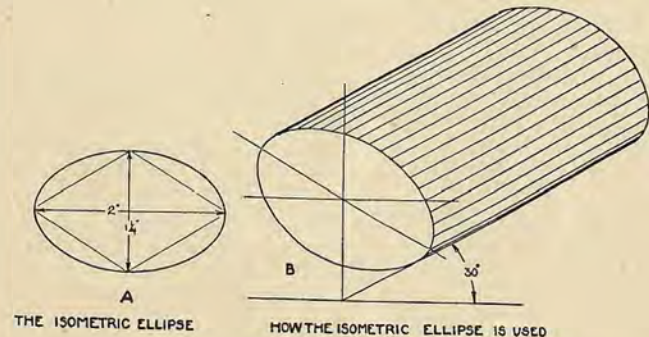

Fig. 8

Now at whatever height you want the box draw two more 30 degree lines parallel with the first two, and whatever width and length you want the box draw two more 30 degree lines parallel with the last two. All you have to do now to complete the box is to draw a vertical line, parallel with the first vertical line, at the corners of the top, and **presto!** The box stands out in relief just as it will look when it is done, nearly, as shown in Fig. 7.

### How to Draw Isometric Circles

In drawing some objects such as a wheel or a cylinder, you cannot show them in an isometric drawing as true circles for it is in perspective and hence, a circle is seen as an ellipse. In this case, however, you can use an ellipse of a given proportion no matter how small or how large you have to make it.

All you need to do to draw such an ellipse is to make its **minor axis**, that is its greatest width,  $\frac{5}{8}$  inch and its **major axis**, or greatest length 1 inch, as shown in Fig. 8. If you want the ellipse smaller or larger stick to the proportions of  $\frac{5}{8}$  inch and 1 inch, by which I mean you can make it  $\frac{5}{16}$  inch wide and  $\frac{1}{2}$  inch long, or  $\frac{1}{4}$  inches wide and 2 inches long, etc. These proportions will give you an ellipse that will be sufficiently close to the proper form so that you can picture anything having a circular figure.

### About the Materials and Tools You Use

**Drawing Paper.** You can use any kind of paper to draw on but for ordinary pencil drawings **manilla paper** is good and it is also cheap. If you are going to make a drawing to keep you ought to get what is called **Whatmans' cold pressed paper** (you can buy it at Kueffel & Essers, Fulton Street, New York City, or of any dealer in drawing materials) and especially so if you intend to ink it in.

**Thumb Tacks.** These are thin, short, sharp tacks with large flat heads so that you can push them into the drawing board by merely pressing on them with your thumb. In putting a sheet of paper on the board push a thumb tack through the upper left hand corner of it, then draw the paper tight and push a tack in the lower left hand corner; this done put a tack in each of the other corners. Thumb tacks are also easy to pull out of the board.

**Lead Pencils.** Pencils are of varying degrees of hardness and show to how hard, they are stamped with the letter H and sometimes with a figure. Thus HHHH or 4H, is a fairly hard pencil and it is a good one, for you to use, especially if you do not intend to ink in the drawing.

**Erasers.** Use a soft rubber for rubbing out lines and sponge rubber, or **art gum**, for cleaning them.

**Drawing Ink.** India ink is always used for inking in drawings because it is thicker than writing and it makes a perfectly opaque black line. You can buy a stick of India ink and rub it up in a saucer with a little water as you need it. Or better you can buy it ready mixed and this I advise you to do. Higgins' prepared India ink is good.

### How to Ink in Your Drawings

To merely make a drawing that you can work from, you only need to pencil in the lines, but if you want to keep it you must ink them in, that is go over the pencil lines with India ink.

**Drawing Pens.** For this work you cannot use a common pen because it isn't of the right shape. The pen for mechanical drawing is entirely different from an ordinary writing pen.

For inking in straight lines with a rule or a scale, a **ruling pen** is used, see Fig. 9. A ruling pen has two steel blades that are fixed at the top and which are parallel when no pressure is applied to them. They are, however, joined together with a screw adjustment so that they can be brought close together and this permits you to make lines of whatever width you want.

To draw circles whose diameters are over half an inch you can use a drawing pencil or pen point that can be slipped into the hollow leg of your compasses. The way to use a pair of compasses is shown in Fig. 2. But if you want to draw circles that are very small, that is anything less than  $\frac{1}{2}$  inch in diameter, you must use a **bow pen**, Fig. 10, that is a pair of little compasses whose legs are connected at the top, not with a joint but with a piece of stiff spring steel; then, too, like the ruling pen, there is a screw adjustment by which you can screw the legs closer together or by unscrewing the nut the spring pushes the legs farther apart.

**How to Fill the Pen.** If you rub up your own India ink, dip an ordinary steel pen into it and then touch the inside of your drawing pen with it when the ink will fill it. When you buy a bottle of prepared India ink you will find a pointed quill fixed to the bottom of the cork and it is easy to fill the pen with it. After you are all through inking in your drawing wipe the ink from the pen clean as the acid in it tends to rust the steel.

### The Use of Scales

A **scale** is a rule that is marked off into inches and fractions of an inch, so a rule is also usually a scale. A very convenient kind is the triangular scale. It is not only much easier to use than a rule or flat



INK GOES BETWEEN  
BLADES

Fig. 9

scale, but it is graduated so that you can enlarge or reduce drawings without having to figure out the proportions for each measurement. You should by all means get one and learn to use it.

### Line Shading

In explaining how to draw plans and in perspective I did not say anything about **shading**. Now nearly all pictures can be made to stand out much better if they are shaded, and this is particularly true of cylinders, especially if the ends are shown as straight lines.

The principle of shading cylinders is shown in Fig. 11, as well as the effect it produces. To shade a cylinder you do not need to draw the end of it and space it off as at A, Fig. 11, but just draw a lot of parallel lines making them very close at the sides and gradually getting them farther apart as they approach the middle.



Fig. 10

### How to Make a Tracing

To make a tracing you need only to pencil the lines on the paper. Then lay over it a sheet of **tracing cloth or tracing paper** (tracing paper is very cheap as against tracing cloth and will serve your purpose just as well) and fasten them to your drawing board with thumb tacks. As both tracing cloth and tracing paper are transparent the drawing shows through them and all you have to do is to follow the lines with your pen.

You will find that one side of both the cloth and the paper is smooth and the other side is dull and you can use either side but it is easier to draw on the dull side. Draughtsmen however, usually prefer the smooth side. Before you begin to make the tracing rub the surface of the cloth or paper with some powdered chalk and then wipe it off with a soft cloth. This will prevent the ink from running or blotting.



A

Fig. 11

### How to Make Blue Prints

If you want one or more copies of your drawing all you have to do is to make, or have made, some **blueprints** of it. The paper that is used for making the prints is called **blue-paper** and you can get it at

any photographic supply house or where drawing tools are sold.

You must also have a photographic **printing frame**. Put a clean sheet of glass in it, then lay your tracing with the inked in lines uppermost, next the sheet of blue paper with the coated side down on this, and spring back into place. Now set it where the sun will shine on it. After a few minutes take the blue paper out, let the water run on it, or soak it in clean water, until all of the lines are white and hang it up to dry.

This is all there is to it and you will have a print that is deep blue, except where the ink lines prevented the sun from acting on it and these will be a clear white.

### A Word About Lettering

To complete a working drawing it is necessary to mark in the dimensions and sometimes the names of the different parts, as well as your own name at the bottom. Unless this is done neatly the drawing, however well done, will look bad.

Some boys have a natural knack for lettering well but others find it a hard thing to do. To explain how to do lettering takes considerable space which I haven't got in this article. But get your drawing material all together and in another number of **Toy Tips** I will tell you how to learn to letter in the easiest way.



# THE THEORY OF WIRELESS

By A. Frederick Collins

The first experiments that had a bearing on **wireless telegraphy or radio-telegraphy** as it is now generally called, were made by Huggens, a Dutch philosopher, who explained in 1678 the action of **light** by waves in what he termed the **ether**.

There the matter rested in-so-far as radio-telegraphy was concerned until 1840 when Henry, an American Scientist discovered that the discharge of a Leyden jar\* set up **oscillating electric currents**. The exact nature of the oscillating current discharge was explained twelve years later by Lord Kelvin a British physicist.

Then, in 1865, Maxwell, a British mathematician, worked out the theory that the light waves of Huggens were electric and magnetic forces which were set up in, and transmitted by and through the ether and hence, these waves were called **electro-magnetic waves**. Since light waves are set up by the vibrations (oscillations) of electric charges of

a flame, Fitzgerald, an Irish investigator, reasoned in 1883 that the oscillating currents of a Leyden jar, or other condenser set up electro magnetic waves in a like manner.

The first actual experiment which proved that this was true was made by Hertz, a German experimentalist, who not only showed that the discharge of a condenser actually set up electro-magnetic waves or **electric waves**, as he called them for short, but how to detect them at a distance, and, also that they were in all respects exactly like light waves but could not be seen as they were far too long.

Hertz's apparatus for producing electric waves consisted of a pair of metal plates connected by brass rods to the spark-balls as shown in (Fig. 1) and this he called an **oscillator**. To this oscillator, which is really a kind of condenser, an induction coil was connected in order to charge it with high pressure electricity. When the oscillator is charged it breaks down the air-gap and streams of sparks fill it, and this gives rise to oscillating current, that is currents which surge from one



Fig. 2

\*These are often called wireless waves and radio-waves.

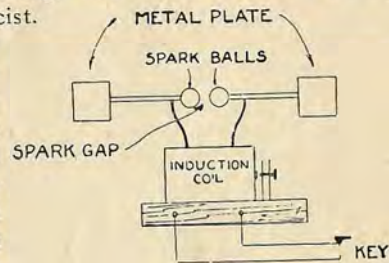

Fig. 1

plate to the other, several million times a second. In turn these oscillations send out electric waves in every direction through the ether.

To detect the waves Hertz used a wire ring with a very small air-gap in it as shown in Fig. 2. On holding the ring detector or **resonator** as he called it, a few feet away from the oscillator which was sending out the waves little sparks would fill the air-gap. This was the first apparatus ever made which would produce and send out electric waves at the operator's will and which could receive and make their presence known at a distance.

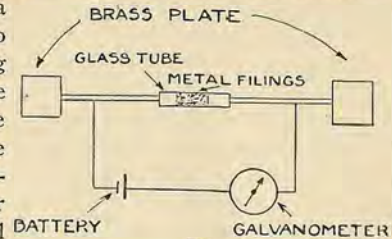

Fig 3

Then, in 1890, Brauly a French physicist devised a very much more sensitive detector than the Hertz ring. This consisted of a tube with metal filings in it and on which the pressure could be adjusted. Brauly called this detector a **radio-conductor** and which later on was called a **coherer**. It was connected in between two metal plates with a battery and galvanometer shunted around it as shown in Fig. 3.

Now when electric waves sent out by a Hertz oscillator impinged upon the plates of the Brauly receiver, they set up oscillating currents in it and these surged forth and back through the filings and covered



Fig. 4

them, that is the filings were drawn together which lowered the resistance so that the current from the battery could flow through the detector when it would move the galvanometer needle.

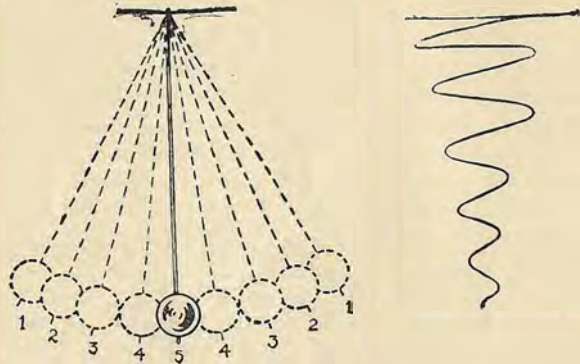
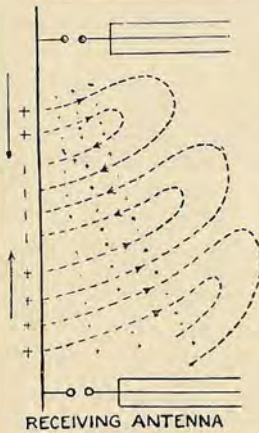

Fig. 5

Popoff, a Russian meteorologist, made the next improvement in 1895, when he connected one side of a Brauly coherer with a metal rod that projected into the air and the other side with the ground. Shunted around the detector was a relay which worked an electric bell. This receiver was used by Popoff to indicate electrical storms which might be far below the horizon and whose lightning discharges sent out long electric waves.

## TRANSMITTING ANTENNA



## RECEIVING ANTENNA

Fig. 6

This was the state of the art when Marconi an Italian student and a mere boy made and used the first complete apparatus for **radio-telegraphy**, or wireless telegraphy as it was then called and is still called so in England. His transmitter consisted of an **antenna**, or wire supported vertically in the air and a ground connected to opposite sides of the spark-gap of an induction coil. His receiver was very much like Popoff's, but he added an automatic Morse register to it which printed the incoming signals on a paper tape.

## What the Ether Is

There is no such thing as a vacuum, for all space is filled with a form of matter so high in the scale that we can neither **sense** it nor have we any instruments sensitive enough to detect its presence, and it is this that we call the **ether**.

Sir Oliver Lodge, the great British scientist has said that the ether may be made up of negative and positive electricity and that therefore when it is **sheared**\* negative and positive electricity is produced. Whatever it may be it is a continuous substance which when set into vibration produces light and other electric waves that travel through it at a velocity of 186,000 miles a second.

## How Electric Waves are Sent Out and Received

If you throw a stone into a pool of water as shown in Fig. 4 at **A** it will send out circular waves in all directions on its surface and if you have previously placed a clip on the water at **B** when the waves strike it it will move up and down. Here then you have an **analogue** of a radio telegraph system, **A** being the transmitter and **B** the receiver.

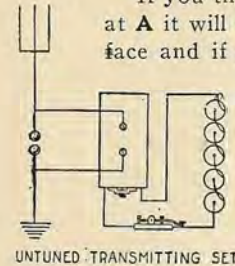

UNTUNED TRANSMITTING SET

Fig. 7

to and fro until it comes to rest. A swinging pendulum and a train of electric oscillations are represented in Fig. 5.

When the oscillations surge through the antenna they set up electric waves in the ether as shown on the cross section diagram Fig. 6. The electric waves spread out in circles from the antenna just as water waves do from around the stone, growing ever larger, getting higher and higher and weaker and weaker the farther they get from the antenna.

As the electric waves are circular they will strike the antenna of a distant sta-

\*Any means which separates the negative electricity from the positive shears the ether.

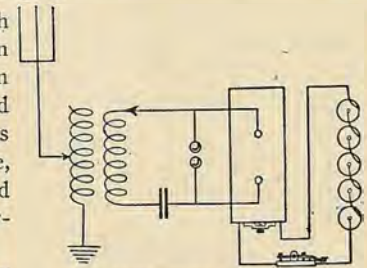

TUNED TRANSMITTING SET

Fig. 8

tion whatever its direction may be; and when the waves do impinge on the antenna of a receiving station, see Fig. 6, their energy is changed into oscillating electric currents just like those of the sending antenna that emitted them, but with this difference, they are very weak. As the oscillations surge through the detector, they act on the magnets of the head phones and make them buzz out their signals.

### The Apparatus of a Simple Sending Station

A simple sending set of the early Marconi type is shown in Fig. 7. It consists of (1) a battery of 6 or 8 dry cells, (2) a telegraph key, (3) an induction coil, (4) a spark-gap, (5) an antenna and (6) a ground.

The induction coil, or **spark coil** as it is often called, is formed of a coil of thick wire, called the **primary coil**, wound on a soft iron **core**, and a coil of fine wire wound on the secondary coil. It is also fitted with an interruptor which rapidly makes and breaks the primary current. The battery, which gives a low voltage current, is connected with the key, the interruptor and the primary coil, while the terminals of the secondary coil are connected with the balls of the spark-gap and these in turn to the antenna and ground.

### How the Simple Sender Works

When the key is closed the **low voltage, direct current** from the battery flows thru the interruptor and the primary coil. The interruptor breaks up the direct current into an intermittent direct current and this sets up **high voltage alternating currents** in the secondary coil.



Fig. 10

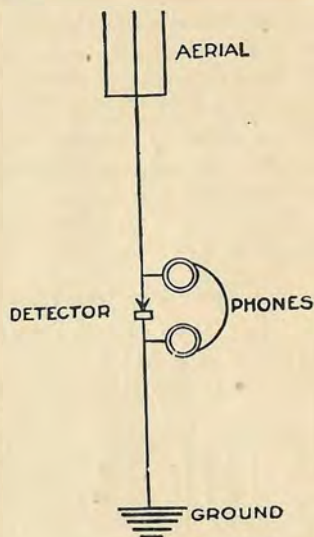

Fig. 9

These latter currents change the antenna and the ground to the opposite signs, that is when one is positively charged the other is negatively charged. When the changes are great enough they break down the air in the gap between the balls and the two changes rush together to equalize the pressure and so set up current of high frequency that oscillates up and down the antenna when electric waves are sent out as I have previously explained.

This kind of a sending apparatus can send out only waves of one length and it cannot be tuned, hence its use is not permitted by the Government.

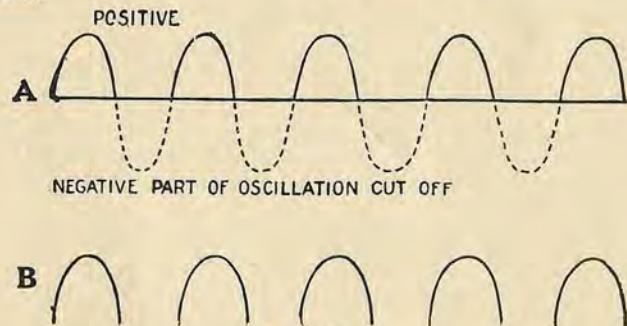

Fig. 11

### The Apparatus of a Tuned Sending Station

As for the simple sending station the apparatus for a tuned sending station consists of (1) a **source of low voltage current** and this can be either (a) a direct current from a battery or service wires, or (b) an alternating current from service wires, (2) a telegraph key, (3) an induction coil, or an **alternating current transformer**, (4) a **spark-gap**, (5) a **condenser**, (6) an **oscillation transformer**, which is a tuning coil, (7) an **antenna** and (8) a **ground**, all of which are shown in Fig. 8.

The alternating current transformer is made like an induction coil only it has no interruptor and hence it must be connected with the alternating current service lines. The secondary terminals of the transformer are connected with the spark gap. The **closed oscillation circuit** is formed of the spark gap, the condenser and the **primary coil** of the oscillation transformer, while the **open oscillation circuit** is made up of the secondary coil of the oscillation transformer as is also shown in Fig. 8.

### How A Tuned Sender Works

Up to the point where the secondary terminals are connected with the spark gap the induction coil or alternating current transformer, the action of the tuned sender is exactly like that of the simple sender described above. In the tuned sender the high voltage alternating current developed in the secondary coil of the induction coil, or alternating current transformer, changes the condenser of the closed oscillation circuit and when the change is great enough it breaks down the air of the gap and it is filled with sparks.

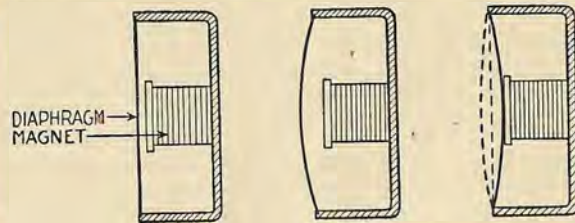

Fig. 12

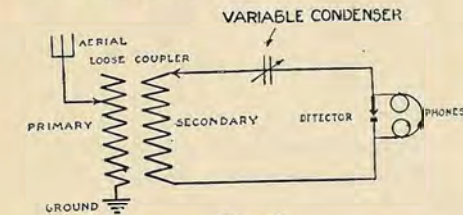

Fig. 13

oscillation circuit; this sets up oscillating currents in the open circuit, the chief part of which is the antenna and this radiates the energy of the oscillations in the form of electric waves.

The closed circuit can be **tuned**, that is made to set up oscillating currents of whatever frequency you want, within limits, by varying the number of plates of the condenser and the number of turns of wire in the primary coil of the oscillation transformer, while the open, or antenna circuit can be tuned to the close circuit by varying the number of turns of wire of the secondary coil of the oscillation transformer.

The wave length that an amateur can use must not be more than 200 meters†, commercial stations operate on from 300 to 600 meter

\*To learn about induction read any text books on physics.  
†1 Meter = 39.37 inches, or approximately 3¼ feet.

lengths; a few stations use wave lengths of 1000 to 1500 meters while the big Government station at Arlington, Virginia sends out its messages on a wave length of 2500 meters.

### The Apparatus of a Simple Receiving Station

A receiving set in its simplest form is shown in Fig. 9. It consists of only four parts and these are (1) a **detector**, (2) a pair of **head phones**, (3) an **antenna** and (4) a **ground**.

The simplest detector is formed of a piece of some kind of crystal about the size of a pea. Silicon, carborundum, galena are some of the many crystals used for detectors. The crystal is held in a fixed position while the point of a fine wire which is attached to an adjusting screw makes contact with the crystal as shown in Fig. 10. The head phone is made like an ordinary telephone receiver but the magnet is wound with finer wire and the diaphragm is thinner which makes it very much more sensitive.

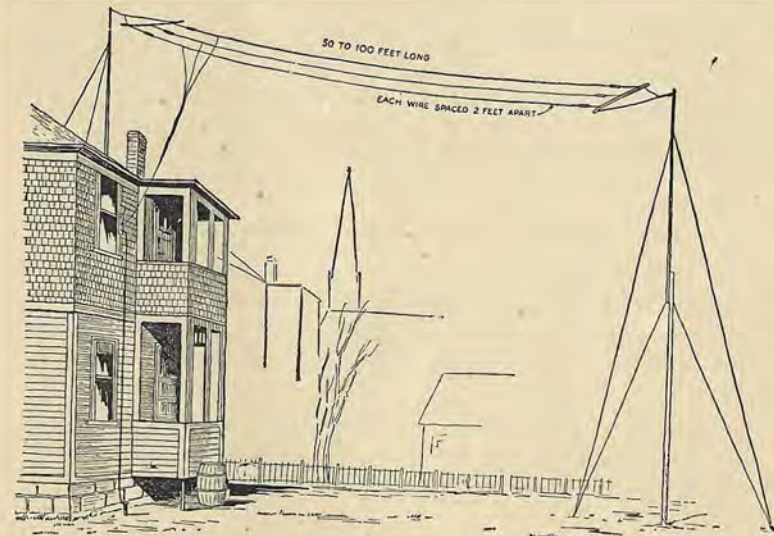

Fig. 14

### How the Simple Receiver Works

When the electric waves from a distant sending antenna strike the receiving antenna they are changed into electric oscillations which surge forth and back from the free end to the ground. As the crystal detector is connected in between the antenna and the ground the oscillations must pass from the wire point to the crystal and the other way about.

The curve shown at **A** in Fig. 11 represents the oscillations as they are set up in the antenna. Now a crystal has the peculiar property of allowing the positive part of an electric oscillation to flow through it more easily than it does the negative part of it; the result is that it then becomes an intermittent direct current as shown at **B** and this flows through and energizes the head phones.

The reason that an oscillating current will not act on the head phones until it is **rectified** as it is called, is because the iron core of the phone magnet cannot magnetize and de-magnetize anywhere nearly as rapidly as the current oscillates and this makes the iron core choke off the oscillations. But where the positive part of an oscillating current only flows through the coils of the phone magnet it acts just like an ordinary direct current. The magnet makes the diaphragm vibrate, see Fig. 12, which sets up waves in the air and when these strike the drum of the ear they set up the sensation of sound as we hear the signals.

### The Apparatus of a Tuned Receiving Station

As in the simple receiving station the apparatus for a tuned receiving station consists of (1) the **antenna**, (2) the **ground**, (3) the **detector**, and (4) the **head phones**. It has in addition (5) an **oscillating transformer**, which is a **tuning coil**, and is commonly called a **loose coupler** and (6) a **condenser**.

The primary coil of the loose coupler is connected in between the antenna and the ground and this forms the **open oscillation circuit**. The secondary coil of the loose coupler, the small variable condenser and the detector is connected together and these form the **closed oscillation circuit**, while the head phones are shunted around the detector all of which is shown in Fig. 13.

### How the Tuned Receiving Apparatus Works

When the electric waves from the distant sending antenna strike the receiving antenna they are changed into electric oscillations as before described. As the oscillations surge from the free end of the antenna, through the primary coil of the loose coupler, to the ground their energy is transferred by induction from the primary to the secondary coil of the closed circuit; there the current oscillates through the condenser and the detector, which latter rectifies it when it acts on the head phones.

As the turns of the primary and secondary coils of the loose coupler can be cut in and out and as the condenser is variable, it is not only easy to tune the open and closed circuits to each other but to tune the receiving station to the sending station.

### About the Antenna

Very few amateur stations have antennae which are under 100 feet in height. For ordinary work an antenna 50 feet high will give you very good results. The length of an antenna for amateur work can be anywhere from 30 to 200 feet long.

One wire can be used for the antenna but three or four are better and these should be spaced about 2 feet apart. Its length will very largely depend on the conditions where it is to be put up. You can often stretch the wires between houses, or from a house to a tree; these supports lacking you will have to erect a mast as shown in Fig. 11.



## CHEMISTRY EXPERIMENTS AND HOW TO PERFORM THEM

Boys, do you realize that, today, this country is entering upon a new era in its history? Until within the last six or seven years or the time of the great World War the importance and significance of Chemistry to a nation was not fully known. Many of the nations before the war were content with importing some of the most important materials of everyday life, such as dyestuffs, drugs, glassware, rubber, copper, platinum, nitrates for fertilizers and explosives, etc. During the course of the war many of these materials were suddenly found wanting by the different nations. The result of this embargo or shutting off of these materials was the manufacture of these materials at home and the greatest boom that Chemistry has ever known. The different nations realized that to be victorious they must cultivate their own resources to the limit. The effect of the war upon the development of the Chemical industry in this country has been exceedingly remarkable. Some of the materials mentioned above and which were almost entirely imported into this country before the war from foreign countries are now being manufactured here and produced in very fine quality. To cite a specific case, we might consider that of the manufacture of dyestuffs. Before the war Germany was the master of this wonderful industry and most of the world was dependent upon her for dyestuffs. You probably experienced difficulty during the early days of the war in obtaining clothing—certain colors of which were fast and did not run. Today we are in a different position. Millions of dollars are invested in this wonderful industry in the United States and dyes are being made which are in some cases superior to those being made in Germany. The fact that Germany had developed her dye industry so tremendously is what enabled her to be so well prepared for and to carry on the war. Dye factories contain much of the necessary equipment and chemicals for the manufacture of explosives and poisonous gases. It is for this reason and the fact that Germany was able to find substitutes for cotton, copper, wool, rubber and other essential materials that she was able to prolong the war. You can readily see, therefore, that it was the chemists of Germany who were able to save her from an early disastrous defeat. The fact that these chemists were able to keep Germany on her feet so long during the war has made the world realize the importance of this wonderful science.

The future prosperity and peace of the world depend upon the attitude taken by the allied nations as regards the development and protection of their chemical and allied industries. Are we going to allow ourselves to drift back into the position we held before the war or shall we benefit by our mistakes and thereby guarantee health, peace and prosperity to our people in the future? We are entering upon a very important crisis. Do you realize that today—right now—Germany is mobilizing her industrial forces and will be ready when the time is ripe to unload her materials on foreign markets at a cost which would send our factories to the wall? By so doing she might regain trade supremacy and be in a position to again threaten the peace of the world. In order

to prevent a recurrence of such misfortunes it is essential that the nations protect themselves. This can be done by encouraging and fostering chemical research. The general public must help in supporting great chemical research laboratories of universities and technical schools and it is very essential that manufacturers co-operate in every way in the commercial development of research. Lastly, our industries must be protected by a tariff on imports. It is up to Congress to take sufficient measures to keep our industries intact and thereby establish our independence of any unscrupulous nation.

Aside from what has just been said, it is very important that every one know something about chemistry because of the fact that chemical phenomena or chemical reactions are taking place around us every day. The changes that take place in salts, minerals, in the ground in our fields, the transformation of some of the constituents of the air into food products such as corn, wheat, potatoes, etc., the transformation of ores from the ground into steel and alloys for ships, buildings, bridges, guns, etc., are just a few of some of the important chemical changes which are constantly brought about around us. Besides there are different chemical phenomena, all life itself is daily undergoing a series of chemical changes or reactions. From our birth to our death we are constantly undergoing changes which are chemical in nature. A knowledge of some of the fundamental things of chemistry as pertaining to the body, would often save many of the average laymen untold suffering and probably life itself. The death-rate of the United States Army, due to sickness and disease during the last war was far below that of the Civil War. This is because of the remarkable advancement that chemistry has made in the science of medicine. In fact chemistry enters into all branches of science either directly or indirectly.

Until recently chemistry had been regarded by the average person as a dangerous science. Many people thought that it consisted chiefly in the mixing of certain dangerous substances which nine times out of ten resulted in an explosion. As the average person was able to acquire more and more knowledge about chemistry he began to realize that chemistry was really one of the most important sciences with its sound fundamentals, principles and laws. As he inquired and delved more and more into the subject, he began to see its relationship and application to every day life until today chemistry is regarded as one of the most important and fundamental of all sciences. It is also due to this awakening on the part of the common people that chemistry is making such marked advances in this country.

Chemistry may be defined as that branch of science which has for its object the accurate investigation of all changes in the identity of substances, and the laws, causes and effects of such changes. When we speak of chemistry we include a very broad field. Chemistry proper may be divided into two branches, namely inorganic chemistry or the chemistry of the elements and organic chemistry or the chemistry of plant and animal life.

The number of elements that comprise the inorganic group is in the neighborhood of 85. Most of these elements are obtained from the earth's crust and occur there either in the free state, such as copper, gold, silver and platinum, or in the combined state, such as pyrites (iron sulphide), galena (lead sulphide), chalcocite (copper sulphide), and halite (sodium chloride). These substances as they occur in the earth are known as minerals and that branch of chemistry which has to do with the study of these minerals is called mineralogy. The extraction of metals from these minerals comprises another field of chemistry known as metallurgy. Physical chemistry deals with the accurate study of the relations between chemical and physical properties and phenomena.

Organic chemistry on the other hand, has to do mainly with the chemistry of the carbon compounds and many of these compounds have been built up or produced synthetically in the laboratory. As a matter of fact over 100,000 carbon compounds are now known although many have no commercial importance. Physiological chemistry is that branch of chemistry which deals with the study of the chemical processes or transformations taking place in the body.

Chemistry has often been called a fascinating science, and with much truth, for it surely affords more recreation than any other. The average boy working in his home laboratory, no doubt, derives more pleasure from entertaining his friends with experiments in "chemical magic" than he does from any other part of his laboratory work. This is probably because such demonstrations are very mysterious to the uninitiated and, therefore, afford a never failing source of amusement, both for the demonstrator and his audience.

Some boys are not successful in their demonstrations of "tricks" in chemical magic and this is due without doubt, to the manner in which the experiments are performed or presented. In order to be successful as a conjuror in chemical stagecraft it is quite essential to be scientific in your method of procedure. That is, it is important not to work in a hap-hazard fashion. Many boys fail at the start because they are unscientific or "careless" in their methods of manipulation. Cultivate the habit of carrying out the details of your experiments accurately and of knowing at all times what you are doing. These things will have a lot to do with the impression you make upon your friends.

A very interesting and important field of chemistry is that known as mineralogy. Minerals are those materials that make up the bulk of the earth's crust and are called inorganic materials because they have not been made by any of the processes of life. A mineral may be described as a naturally occurring substance of definite and uniform chemical composition and of characteristic physical properties. Mineralogy is that branch of science which has for its object the accurate investigation of these naturally occurring products as regards their physical and chemical properties, their economic importance and their uses in the arts.

The question which naturally comes up in every boy's mind is, "What is the value of the science of mineralogy; how can it be shown to be

important not only as a branch of science but important economically or from a commercial standpoint?" The answer to this question is very easily understood when you realize that, today the prospector and mining man depend upon the economic mineralogist in searching for mines or handling ores and minerals. Sometimes valuable mines or worthless ones are reported on unfavorably by men not familiar with the principles and details of mineralogy. Again large sums of money may be lost by wrongly carrying out certain operations such as ore dressing. It can be seen therefore, that a knowledge of mineralogy—especially economic mineralogy—is a very important asset to the miner, prospector and metallurgist. This is the bigger aspect of the importance of mineralogy as a science. The other aspect, and one which ought to appeal very strongly to boys, is the fun derived from knowing how to identify or spot on sight different minerals as you find them either alone or in the rocks in nature. As you become acquainted with the habits, forms, properties and peculiarities of the different minerals you will be able to picture all of these things in your mind on finding some of the minerals in nature. You will become much interested in nature and will really see more things which before meant practically nothing but are now of fascinating interest to you. Then again you may come across a mineral which you are not able to identify by sight. You cannot appreciate the fun there is in applying chemical and physical tests to these minerals and establishing for yourself the name of the unknown mineral.

Electricity is very closely related to chemistry and many large and important industrial concerns are engaged in manufacturing materials involving the use of electro-chemical reactions. Today chlorine gas and caustic soda are manufactured by passing an electric current through salt water. From the chlorine gas we obtain bleaching powder. Metals are extracted from their ores by passing a current through their molten or fused salts. Nickel plating, copper plating and gold plating are done by passing a current through a solution containing salts of these metals. The success of these important industries and many others is based on the fact that electricity possesses the power of decomposing chemical compounds.

On the other hand, the relationship between chemistry and electricity can be shown in another way. As you may know, electricity is a form of energy. Now, in most chemical reactions, heat is liberated as the form of energy. However, under proper conditions, the energy of certain chemical reactions is liberated in the form of electricity. For example, if a copper plate and zinc plate are placed in a solution containing an acid and the two plates connected with copper wires, a current of electricity is produced. A reaction takes place in which electricity is the form of energy liberated. Use is made of this fact in the manufacture of the different types of electric cells and batteries. Batteries are simply cells connected together in series in order to produce a stronger current. There are several types of cells, all of which come under two classes, namely, the primary cells, which include the dry and wet cells, and the secondary cell or storage battery as it is called.

Finally, a third relationship of electricity to chemistry may be mentioned. That is, the part electricity plays in furnishing heat to produce chemical change. A good example of this is the manufacture of graphite from carbon by means of the electric furnace. Also the manufacture of calcium carbide for the production of calcium cyanamide, used in fertilizers, of nitric acid from nitrogen in the air and many other important industries depend upon the heat generated by the electric current for their success.

The following experiments will be found to illustrate just a few of the practical applications of chemistry to every day life and will afford no end of fun for you and your friends.

### Experiment 1 — How to Make Soap

Make a solution of caustic soda or lye by putting 1/3 teaspoonful each of Sodium Carbonate and Calcium Oxide into a test tube 1/2 full of water and boil over a flame for 2 or 3 minutes, holding the mouth of the tube away from you. Allow the tube to cool and when the liquid has settled pour the clear liquid into another test tube. Now add a piece of lard or butter about the size of a marble and boil the liquid again for a few minutes, being careful that the liquid does not bump out of the test tube. You can prevent this by shaking the tube in the flame while heating. Notice that the lard or butter dissolves very readily in the hot alkali.

Now add 1/3 teaspoonful of common salt and heat the mixture again for 2 or 3 minutes. Allow the contents of the tube to cool and notice that the soap separates out as the upper layer. The liquid layer below contains glycerine, salt, and impurities. Try washing your hands with the soap you have made.

### Experiment 2 — How to Test Soap for Alkali

Test samples of household soap, both laundry and toilet soaps for free alkali by cutting a fresh surface on the soap with a knife and dropping on to the surface 1 or 2 drops of Phenolphthalein solution or a small piece of moistened red litmus paper. If the phenolphthalein turns red or the red litmus paper turns blue the soap contains free alkali.

Laundry soap usually contains free alkali. Toilet soap should be nearly or quite free of alkali as it roughens and chaps the skin.

### Experiment 3 — Testing Cloth for Cotton, Wool or Silk

If a textile expert wishes to know what percentage of wool or cotton there is in a sample of cloth containing both of these fibers, he simply washes and dries the sample, weighs it accurately and then treats it with a boiling solution of caustic soda. The soda dissolves out the woolen fibers leaving the cotton fibers unchanged. He then removes the cloth, washes it with water and dries it. By weighing again and getting the difference in weight, he can easily calculate the percentage of cotton and wool in the cloth.

Put 1/3 teaspoonful each of Calcium Oxide and Sodium Carbonate in a test tube 1/2 full of water. Boil the solution for several minutes and when the solution settles pour the clear liquid into another test tube. This is sodium hydroxide solution. Now add to this liquid a piece of woolen yarn and boil for 2 or 3 minutes. Notice that the wool dissolves. Put in a small piece of silk and boil again. Notice that the silk dissolves also. Then add a small piece of cotton cloth and notice on boiling that it will not dissolve, proving that the cotton fiber is not attacked by alkalis and can be distinguished from true silk by means of this test.

### Experiment 4 — Magic Fountains

Fit a flask as shown in the cut with a cork and short glass tube. The tube is drawn out to a point at one end so as to leave a small opening and should project about one inch into the flask, as shown in Fig. 1. The cork is now removed and the flask filled with ammonia gas by displacing the air. The cork is again placed in the mouth of the flask and the outer end of the tube dipped into a dish full of water containing a little red litmus solution. The red litmus solution immediately passes up thru the tube forming a fountain in the flask, the red color of the liquid changing to blue. This effect is caused by the red litmus solution dissolving the ammonia gas thereby producing a vacuum in the flask. The color change is due to the fact that litmus solution is blue in the presence of an alkali like ammonia.

Red litmus solution is made by adding two or three drops of acetic or tartaric acid to blue litmus solution. The color of the solution should not be too deep.

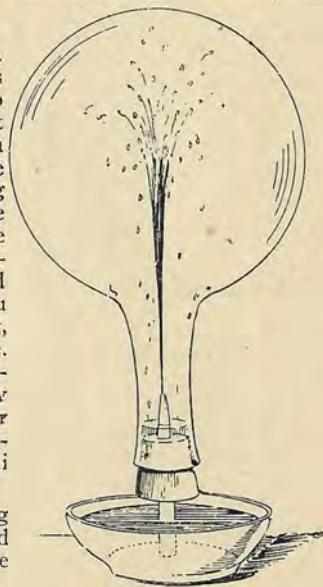

### Experiment 5 — Magic Crystal Effect

Make a solution of camphor by dissolving a little camphor in some alcohol. Pour some of this solution on to a clear cold sheet of glass and observe that the camphor immediately crystallizes into beautiful tree-like forms.

### Experiment 6 — Extraction of Metals from Their Ores

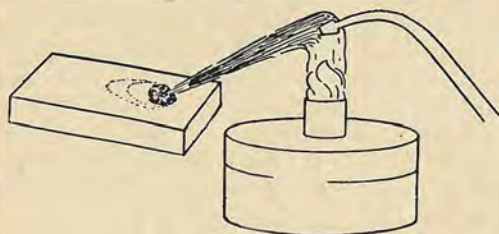

Make a small cavity on one side of a piece of charcoal and put into it a small amount of powdered mineral Galena (lead sulphide) and an equal amount of Sodium Carbonate. Heat this mixture in the reducing flame of the blowpipe as shown in the cut. Notice that a metallic globule of lead is formed, which is bright lead color when hot but covered with a dull oxide coating when cold. Notice that a coating of lead oxide is also formed, which is yellow near the globule and white farther away. Remove the globule and notice that it is malleable and can be hammered out into a thin sheet.

This experiment illustrates the principle of reduction as it is applied to the extraction of metals from their ores. Repeat this experiment using a little of the minerals azurite (basic copper carbonate) and pyrite (iron sulphide) and notice the formation of metallic copper and metallic iron.

### Experiment 7 — To Illustrate the Principle of Copper-plating

The simple process of transferring metal from one object to another by chemical and electrical means is called electro-plating. By this method, objects are copper-plated, silver-plated and gold-plated. If you have any medals which you wish to copper-plate proceed as outlined in this experiment.

The object to be plated must always be cleaned of oils, grease or varnish. This can easily be done by boiling the object in vinegar or in a solution of sodium carbonate for several minutes. When cleaned the object must never be touched with the fingers, for if it is a film of grease will be left and the plating will not stick to the surface.

Dissolve 1 spoonful of Copper Sulphate in a tumbler half full of water. Now using two or three dry cells connected up in series as shown in the cut, attach the medal or other object to be copper-plated to the wire from the zinc pole or negative wire in the manner illustrated. To the wire from the carbon or positive pole of the battery attach a Copper Strip. Now immerse the copper strip and the medal in the copper sulphate solution, being sure that the medal to be plated is below the surface of the solution. Do not allow the copper strip and medal to touch. In a few minutes you will note that the medal is covered with a

deposit of copper. Leave the medal in the solution until an even coat is deposited. This should take from 10 minutes to 1 hour, depending upon the size of the object and the strength of the solution. To give the medal a bright finish, rub it lightly with an ordinary pencil eraser.

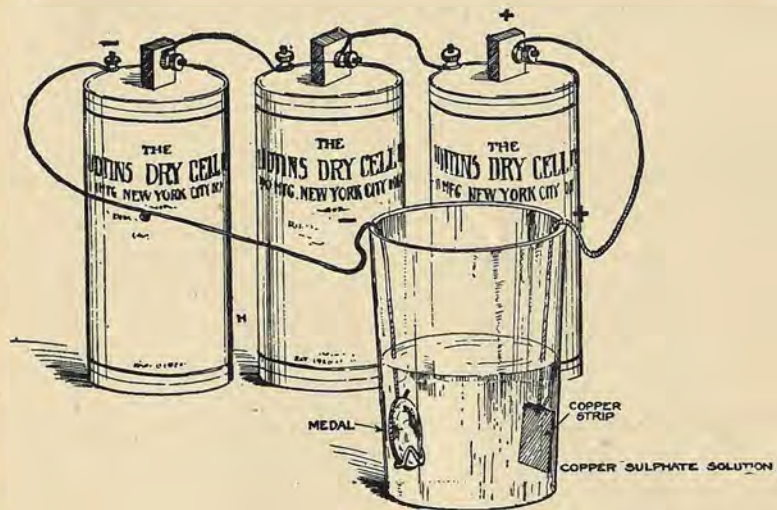

### Experiment 8 — How to Nickel-plate

The object to be nickel-plated must be free of oil, grease and varnish. This can be done by boiling it in vinegar or a solution of sodium carbonate.

Dissolve 1 spoonful of Nickel Ammonium Sulphate in a tumbler half full of water. Now attach the iron, copper or brass object to be nickel-plated to the negative wire and an iron nail to the positive wire. Immerse these in the solution and notice that soon the object attached to the negative wire which goes to the zinc post is covered with a coating of nickel.

## SOME SIMPLE EXPERIMENTS IN MAGIC AND HOW TO PERFORM THEM

Magic is as old as the human race but it is as wonderful as it was when first invented. Here are a few easy tricks that you can do but they are mystifying as any a professional magician ever did.

### The Magic Glass of Water

Of course you know that if you fill a glass nearly full of water and place a card on top you can turn the glass upside down and the pressure of the air on the outside of the card will hold the water in as shown at **A** in Fig. 1. This is a simple experiment in physics.

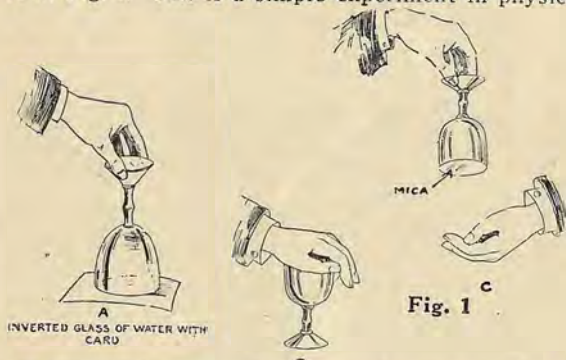

Fig. 1

To make a trick of it cut out a disk of mica, (isinglass) the exact size of the mouth of the glass. Use a wine glass for the trick as it is small. Now palm the mica disk in your right hand and nearly fill the glass with water. Place your hand over the top of the glass as shown at **B** and invert it when the mica

will hold in the water the spectators can't see it, as at **C**.

Moreover you can throw the glass up in the air and no matter what position the glass takes, still the mica will hold in the water. When you have done place your hand over the mouth of the glass and palm off the mica and you can then pour the water out of the glass.

### The Vanishing Handkerchief

Take a fresh egg (and be sure it is fresh) and blow out that part which nature intended should have become a chicken but which man has learned to eat. Now pour into the egg shell some melted paraffin and give it a whirling motion when it will stick to the inside of the shell and form a coating there. You can now cut out one side of it.

To vanish the handkerchief and produce in its place an egg all you have to do is to palm the prepared egg with the hole away from the palm of your hand as shown at

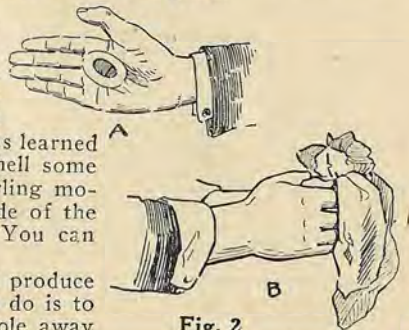

Fig. 2

**A**, Fig. 2. Take a small red silk handkerchief and holding your hands as shown at **B** wave them slowly up and down and to and fro and at the same time gradually work the handkerchief into the egg. Or you can reverse the trick and show the egg first and then change it into the handkerchief.

### The Flying Glass of Water

Another good trick with a glass of water, or it can be used with telling effect as a **finale** to the inverted glass described in Fig. 1 is to take two small colored handkerchiefs that are just alike, sew three of their edges together and tack (with a thread of course) a wire ring that is just the size of the mouth of the glass, in the center between them as shown at **A** in Fig. 3.

To do the trick you must fix a shelf, called a **servante** by magicians, to a table as at **B**. After inverting the glass of water with the mica disk on it set it on your table, well back, throw the handkerchief with the ring over it and grip the ring with the fingers of your right hand as

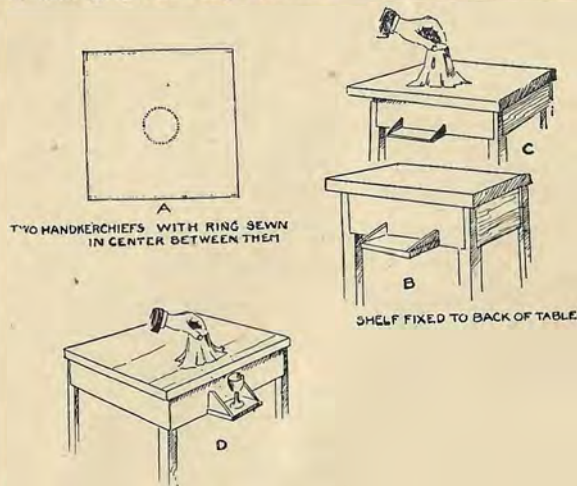

Fig. 3

shown at **C**; at the instant you lift it slip the glass with your left hand from under the handkerchief onto the shelf as pictured at **D**.

Still holding the ring of the handkerchief you carry in into the midst of the audience (who think the glass is still under it), then suddenly throw it into the air and catching it as it falls shake it out and the glass is gone.

### The French Coin Drop

This little trick is called a **pass** and it is not only easy to do but very effective and is useful in many coin tricks. It takes a little practice to it neatly so begin by holding your left hand with the **palm up** and placing a big one-cent piece, or better a half-dollar between your thumb and your index and middle fingers as shown at **A** in Fig. 4.

This done hold your right hand with the thumb down as shown at **B**, move it toward the left hand and pass your thumb under the coin when your fingers will be over it as at **C**. This hides the coin from the spectators and at this instant you let the coin drop into the palm of your left hand, which of course is empty.

To the spectators the illusion is complete as it looks to them as if you took the coin in your right hand. You can then hold up and slowly open your right hand when the coin (apparently) vanishes and with your left hand you can produce it from the nose of a spectator or from some other unsuspecting place.

### The Changing Card Box

This is a very deceptive mechanical trick. It consists of a little flat box that you can make out of a cigar box, as shown in Fig. 5, but you must make a neat job of it. Make the inside of the box  $\frac{1}{8}$  inch wider and longer than a playing card and  $\frac{3}{4}$  inch deep. The top and bottom are both alike, that is  $\frac{3}{8}$  inch deep each, and these are hinged together.

Now paste a spot card and a face card together back to back and lay the card in the box. When you lay the box down one way and open it the spot card will be up and when you lay the box down the other way and open it the face card will appear. You can use the card box with telling effect for many card experiments.

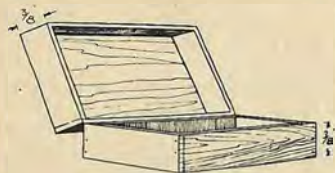

Fig. 5

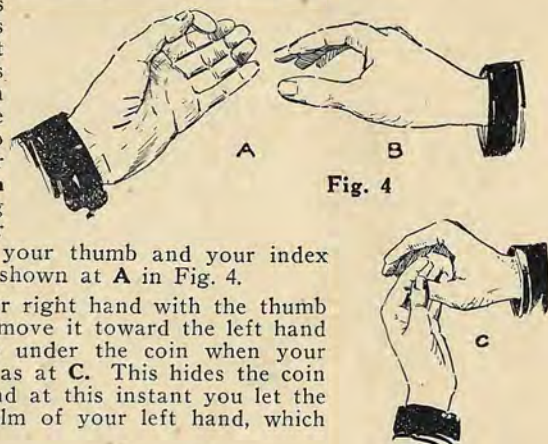

Fig. 4

### The Changing Card

Here is a good little card trick and one that you can do without practice. It is a card that changes from a spot-card to a face-card, and it is known to magicians as a flap-card.

A  
THE SPOT CARDB  
THE FACE CARDC  
THE CARDS PASTED TOGETHERD  
THE FLAP CARD COMPLETE

Fig. 6

Take, say the **Eight of Hearts** and the **Jack of Spades** and cut both in half on the broken lines as shown at **A** in Fig. 5. Now paste half of each of the cards together as at **B**, and paste the other halves of the other two cards together back to back as shown at **C**. Hinge this part of the card to the other part with a bit of muslin as at **D** when your flap-card is done.

Now hold the card in your hand so that the flap will hang down when the card will be seen as the eight of hearts. Give your hand a sudden flip and it will throw the flap up which you grip between your fingers and the card will be seen as the Jack of Spades.

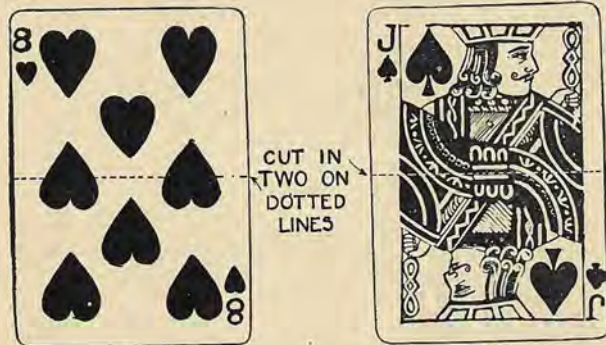
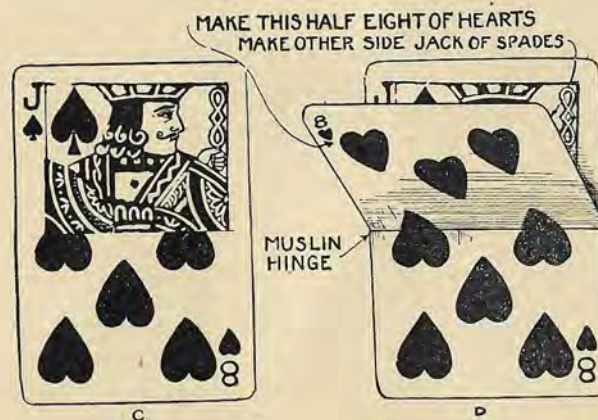

# GILBERT ERECTOR

“THE TOY LIKE STRUCTURAL STEEL”

Join the big family of American Boys — hundreds of thousands of them — who play with Erector, the wonderful Engineering toy.

The big reason why Erector is the choice of so many thousands and thousands of boys is because it's genuine. I guess I've never got over being a boy myself. I know the importance to you boys of having things genuine. So I have studied and worked as hard to make Erector mechanically true as other men do to make a bridge strong or a building architecturally correct.

You can build toy steel bridges, skyscrapers, battleships, machines with Erector and never lose interest in them because they are true. They are exactly like the real thing. Erector girders have lapped interlocking edges (a patented exclusive feature all my own) so you can build with square, four-sided columns, instead of flat strips, and your models are “strong as a horse” instead of flimsy and shaky.

## Get These Big Exclusive Advantages in Erector

The only actual structural steel toy.

The lapped, interlocking edges of Erector Girder, (an exclusive patented feature) enable you to build four-sided and square columns.

Each piece is stamped accurately out of steel.

Each part is scientifically made; correct in design and proportion.

More parts for building strongest and largest model. Every essential engineering part.

Anything mechanical can be duplicated with the Erector.

Big, re-inforced steel wheels, grooved and hubbed for every engineering purpose.

**BIG NEW MANUAL**, showing exceptional mechanical models. In addition to those illustrated, thousands of other models can be built, depending only upon your originality and skill, for there is nothing mechanical but can be duplicated with the Erector.

You will like the real four-sided square girders, the steel angle irons, shaftings, wheels, pulleys, nuts and many other parts that come only with Erectors.



No. 4

## No. 4 Erector

Here's the famous No. 4 Erector. I call it the famous No. 4 for it has always been the choice among boys. This set contains the powerful Erector Electric motor with which you can make your models actually run. It also has a big assortment of parts to build models with and the big Erector Manual showing many models you can build. Motor comes knocked down. Full directions are given in the manual for assembling it. This is the kind of set you'll be proud of. Packed in the distinctive Gilbert Toy carton with four color label, size 19 x 10 x 1 1/4 inches. Approximate weight: 4 lbs., 12 ozs. Makes 278 models. Price \$5.00 (Canada \$7.50).

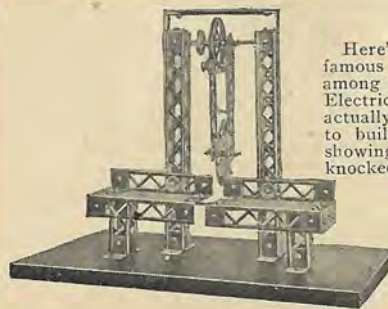

### No. 1 Erector



Just the outfit for a young boy who is beginning with Erector. The parts included are the same mechanically correct girders, angle irons, pulleys, etc., in all Erector Outfits. Then, too, there's a big book of instructions giving complete directions for building many interesting models. Packed in the distinctive Gilbert Toy carton with four color label, size  $12\frac{1}{4} \times 8\frac{3}{4} \times 1\frac{1}{4}$  inches. Approximate weight, 1 lb., 10 ozs. Makes 111 Models. Price \$1.50. (Canada \$2.25).

### No. 2 Erector

A slightly larger Erector outfit than No. 1, containing in addition to the parts in No. 1 the Erector base plate, shaftings, and complete set of bright red wheels for building wagons, trucks, etc. The big book of instructions shows some models that you'll like. Packed in the original Gilbert Toy carton with four color label, size  $12\frac{1}{4} \times 8\frac{3}{4} \times 1\frac{1}{4}$  inches. Approximate weight: 2 lbs., 8 ozs. Makes 152 Models. Price \$2.50 (Canada \$3.75).



### No. 3 Erector

Here's an Erector Set that you'll enjoy. This one includes the standard Erector gears and pulleys, besides a liberal assortment of girders, shaftings, angle irons, base plate, bolts, nuts, screws, etc. With this outfit you can build any number of unique and modern models. The book of instruction included gives complete directions and shows pictures of many fine models. Packed in a Gilbert Toy carton with four color label, size  $19 \times 10 \times 1\frac{1}{4}$  inches. Approximate weight, 4 lbs. Makes 197 Models. Price \$3.50 (Canada \$5.25).



### No. 6 Erector

Here's a dandy set. Contains just the right number of parts for building some great models. There's special gears, plates, standard Erector girders, angle irons, shaftings, wheels, pulleys, nuts and many other parts that come only in Erector Sets. Included is a motor to provide motive power for your car, elevator or derrick models. It will make your model natural looking — make it move in real fashion. There's no end of the pleasure you can get from this set. Packed in a big stained hardwood cabinet arranged to hold the parts conveniently and compactly. Size  $22 \times 8\frac{1}{2} \times 2\frac{1}{4}$  inches. Approximate weight: 8 lbs., 12 ozs. Makes 317 Models. Price \$10.00 (Canada \$15.00).



### No. 7 Erector

A very complete set for the boy who is old enough to make difficult models. It contains many parts for building some big and elaborate models. There is included a motor and a reverse base to operate the crane, derrick or elevator that you make. The fact you use motive power in your work adds to the reality of it. All the parts of the standard Erector equipment packed in stained hardwood cabinet  $17 \times 10 \times 3$  inches. Approximate weight: 10 lbs., 4 ozs. Makes 382 Models. Price \$15.00 (Canada \$22.50).



### No. 8 Erector



An advanced set containing a sufficient number of parts to do most any kind of building. You can build some wonderful models with this outfit, such as locomotives and things requiring care and study. You will not be limited in your work; you can build some very big models requiring a whole lot of girders, angle irons, shaftings, nuts, bolts, etc. Of course, the powerful Erector motor is included, together with reverse base and control switch. Packed in hardwood cabinet size,  $18\frac{3}{4} \times 10\frac{3}{4} \times 3$  in. Approximate weight: 17 lbs. Makes 410 Models. Price \$25 (Canada \$37.50).

### No. 10 Erector

The largest and most complete Erector set made. You can be sure that with the assortment of parts in this outfit you will have no trouble in setting up models of the most difficult machines. There's the cracker-jack Erector motor, reverse base, control switch, girders, angle irons, shaftings, nuts, bolts and everything you could wish. Packed in hardwood cabinet with trays to hold the different pieces in the right place, size  $20\frac{1}{4} \times 12 \times 3\frac{3}{4}$  inches. Approximate weight 30 lbs. Makes 454 Models. Price \$35.00 (Canada \$52.50)



### OUTDOOR WHEEL TOY COASTER MODEL



**PARTS ENOUGH UNDER THE  
SEAT TO BUILD 6 OTHER  
TOYS EQUALLY AS BIG**

Here's the greatest toy of all, boys — a regular humdinger. With these New Wheel Toys you can make a cracker-jack coaster and many other fine things as easy as rolling off a log — a sporty wagon, a dandy geared speedster, a glider that is better than the regular ones, a wheelbarrow, a baggage truck that's the real thing — something new every week.

These toys are not models or flimsy affairs. They are honest-to-goodness ones, exceptionally strong and sturdy—toys that you can get on and ride yourself. All you need is a screw driver and wrench and the parts in the outfit. With them you can build the glider, wagon, coaster, etc., in no time at all. Think what fun you can have building yourself a different toy every day or week or as often as you like. There's no end to the sport my New Wheel Toy will give you. Read over carefully the description of each outfit.

The braces, angle irons, strap pieces, etc. are made of heavy bank iron finished in rubber enamel black. The special disc wheels are made of the best grade steel finish in bright red. Every set includes axles, nuts, bolts, and everything necessary to put the models together.

### No. 9009

Comes set up as coaster with parts enough under the seat to change the coaster into a wheelbarrow, dump cart, wagon, errand coaster, hand truck, or two wheel glider.

Packed in corrugated carton, size  $32 \times 8 \times 9$  in. Approx. weight, 23 lbs. Price \$10.00 (Canada \$15.00)



### No. 9002

Same as No. 9009 but all parts are packed in hardwood box which makes seat of coaster in the illustration. Builds the same models as No. 9009. Size  $14\frac{3}{4} \times 8\frac{3}{4} \times 2\frac{1}{4}$  inches. Approximate weight, 16 lbs., 12 ozs. Price \$10.00 (Canada \$15.00).

### SPEEDSTER MODEL

## Outdoor Wheel Toy



**PARTS ENOUGH UNDER THE SEAT TO  
BUILD 10 OTHER BIG TOYS**

See No. 9010 and No. 9005 Sets.

Comes set up as geared speedster and has parts enough under the seat to change into wheel barrow, hand truck, two wheel glider, errand coaster, dump cart, trailer, coaster, wagon with handle, wagon with shafts, coaster with handle or lawn seat.

Packed in corrugated carton, size 35 x 14 x 9 inches.

Approximate weight, 32 lbs. Price \$15.00 (Canada \$22.50).

#### No. 9005

Same as No. 9010 only all parts are packed in stained hardwood cabinet that forms seat of speedster in the picture. Builds same models as No. 9010. Size 14¾ x 8¾ x 3½ inches. Approximate weight, 26 lbs. Price \$15.00 (Canada \$22.50).

#### No. 9008

Contains in addition to special disc steel wheels and heavy steel braces and angle irons, sled runner and added parts to enable you to use your Wheel Toy on the snow. With this set you can build wheel barrow, hand truck, two wheel glider, errand coaster, wagon with handle, wagon with shafts, coaster with handle, lawn seat, three wheel glider, wagon with handle and runners, wagon with shafts and runners, go-cart, bob sled with handle, dump cart, trailer, coaster, geared speedster. Packed in hardwood cabinet, size 22 x 8½ x 5½ in. Approx. weight, 35 lbs. Price \$25.00 (Canada \$37.50).



## ELECTRICAL SETS

You simply press a button or turn a switch and you have light. Do you know why — or where it comes from? No! Because it's electricity.

What is electricity? I am sorry to confess, that neither you nor I, nor anybody who lived or is living, could answer this question. We do not know what electricity is. We cannot define the idea "electricity," but we can turn to advantage the phenomena of electricity. We can, and we do it. We have mastered this mighty force and made it our powerful servant. We can produce it and use it, and are more the servants of electricity than it is our servant. It is hard to imagine what man's life would be without the use of electricity, and I think the time is not very far off when the height of civilization will not be measured by soap, but by the electric meter.

#### No. 3002

This outfit contains all parts for building a complete motor. Also apparatus and Manual enabling you to find out all about current electricity, electrotyping, electro-plating, how to connect electrical magnetic current, wire electric lights, door bells and other practical every day uses of electricity. This is a dandy set. Packed in Gilbert Toy carton with four color label, size 12¼ x 8¾ x 1¼ inches. Approximate weight: 1 lb., 4 ozs.

Price \$3.00 (Canada \$4.50).



#### No. 3003

The same experiments can be performed with this outfit as with the set No. 3002 and in addition is included Illustrated Manual and apparatus teaching the essential laws of electrical machinery, how to control and reverse current, connect motor multi-gear box, a combination which develops a surprisingly powerful unit for driving models, lifting weights, etc.

Packed in Gilbert Toy carton with four color label, size 18 x 10 x 1¼ in. Approximate weight 3 lbs. Price \$6.00 (Canada \$9.00).



## No. 3004

This little electrical laboratory will teach you the fundamental laws of gears and electric machinery. The set contains a model for an electrical sounder enables you to study and exercise practical telegraphy. By playing with an equipment like this you will be able to understand the dynamo or the generator, the big apparatus used to produce electricity, and many other wonderful electrical things. With each set is a big book of instructions telling you how to perform each experiment. Packed in a hardwood cabinet, size  $18\frac{3}{4} \times 10\frac{3}{4} \times 3$  inches. Approximate weight: 5 lbs. Price \$10.00 (Canada \$15.00).

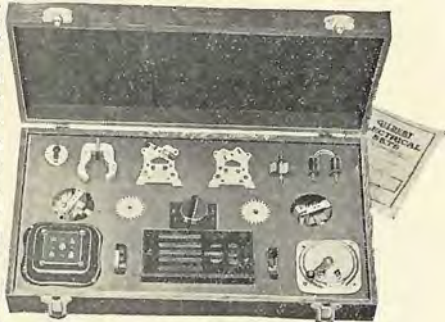

### PHONO SETS

#### Real Working Telephones

Say, boys, here are new electrical sets that are dandies. Real telephone outfits that you can rig up from your house to the house of your chum and talk to him any time you want to. You can have some corking good times. On rainy days, for instance, you can talk to him as much as you want to. Your folks can use them, too. You will have your own private telephone system with no telephone operators to bother you or listen to what you are saying.

## No. 3503

Outfit contains two complete telephone stations, with phones all ready to be assembled, wire and complete book of instructions. Packed in Gilbert Toy carton, size  $18 \times 10 \times 1\frac{1}{4}$  inches. Approximate Weight: 2 lbs. Price \$5.75 (Canada, \$8.65).

#### No. 3506 (Not Illustrated)

Outfit contains two complete telephone stations, same as in No. 3503, and also fitted with bell call system so you can ring up your chum or whoever has the other station. Complete book of in-

structions also included. Packed in Gilbert Toy carton, with four color label, size  $18 \times 10 \times 1\frac{1}{4}$  inches. Approximate weight: 2 lbs., 11 ozs. Price \$10.00 (Canada \$15.00).



## Wireless Telegraph Sets

## No. 4004

Contains one receiving and one sending station, receiver, wire, cleats, and book of instructions. Packed in the Gilbert Toy Carton with four color label, size  $18 \times 10 \times 1\frac{1}{4}$  in. Approximate weight: 3 lbs. Price \$5.50 (Canada \$8.25).

## No. 4005½

Contains two complete receiving and sending stations, together with receiver for both stations, wire, cleats, and big book of instructions. Packed in the Gilbert Toy carton with four color label, size  $18 \times 10 \times 1\frac{1}{4}$  inches. Approximate weight: 4 lbs. Price \$10.00 (Canada \$15.00).



## SEPARATE PHONES

## No. 3507

A real inter-communicating telephone system that will delight any boy. Two complete wall stations that can be rung back and forth like regular phones. A button on each set connects the current, ringing the bell on the other outfit. By lifting the receiver from its hook the bell circuit is automatically disconnected and the talking circuit switched on.

Outfits will operate satisfactorily on two batteries to each station over approximately 300 feet. Just the thing to rig up from attic to cellar, room to room, etc. Complete wiring diagram furnished with each set. Telephone boxes are black japanned metal, mounted on wooden bases  $4 \times 4\frac{1}{2}$  inches. Transmitter mouth pieces and receivers finished in black japan. Bells brightly nickel-plated. Receiver cords approximately 15 inches long. Approximate weight  $1\frac{1}{4}$  lbs. Price \$5.00 (Canada, \$7.50).

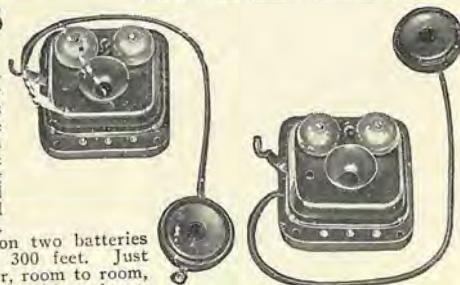

## TELE SET

## No. 3502

This outfit works just like the instruments in the telegraph stations where communications between distant points take place every day, and is just the outfit you want.

In the book of instructions included with the set everything is explained very simply so that it will be easy for you to understand how every part works. After you have used your set and know the code, it will be very interesting for you when in a telegraph office to listen to the instruments they have there. It is well, too, that you become familiar with the code used in Wireless. Then you will be in a position to understand the transmission of messages by this system as well as by telegraphy. This is the game for you — the kind of play that gives you plenty of fun and at the same time teaches you things every boy is eager to know. Packed in Gilbert Toy carton,  $12\frac{1}{2} \times 8\frac{3}{8} \times 1\frac{1}{4}$  in. Approximate weight: 12 ozs. Price \$2.00 (Canada \$3.00).



Gilbert Toy carton,  $12\frac{1}{2} \times 8\frac{3}{8} \times 1\frac{1}{4}$  in. Approximate weight: 12 ozs. Price \$2.00 (Canada \$3.00).

## HYDRAULIC &amp; PNEUMATIC ENGINEERING

No. 6502

Think what it means to you to be able to construct models of water systems — to make trench guns with which you and your chum can have a real battle! Learn how ships that have been sunk are raised — interesting facts about the submarine, the depth bomb, and torpedo. There are many fascinating experiments that you can do to illustrate a great many scientific facts which explain the important inventions so well known today.

A Gilbert Hydraulic and Pneumatic Outfit is an equipment you can use as often as you like and never grow tired of it. After you have read the book of instructions that comes with each set you can use your apparatus to make models of big construction work, build a miniature water supply system of your own, and in many ways get a good knowledge of the big problems engineers have had to solve. All the necessary apparatus for preparing many interesting experiments is included in this outfit. Price \$10.00 (Canada, \$15.00).



## CIVIL ENGINEERING

No. 6525

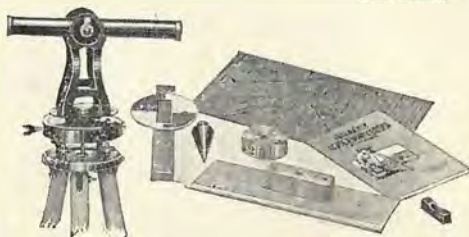

You are very much interested when you are playing baseball or tennis to see that all rules of the games are obeyed. Why not be just as interested about the layout of the baseball field or tennis court? With the Gilbert Civil Engineering set you will be able to lay out your playing field accurately. With your own instruments you can measure distances exactly, make a map of your backyard, putting in the trees, fences, sheds, etc. You can use your apparatus anywhere—

at the camp, perhaps, where it is necessary to get information about the land on which the camp will be located. Find out what the grade of your street is. Learn to lay pipes for drainage. Do many things that the civil engineer does when he is completing a great piece of construction work. With the set comes a fully illustrated book on surveying from which you can obtain a knowledge of how to use your equipments, how to survey, and of the work great engineers have done. The outfit contains all parts necessary for building your own transit. Packed in corrugated cardboard container, size  $15\frac{1}{4} \times 6\frac{3}{4} \times 6$  inches. Approximate weight: 6 lbs. Price \$15.00, (Canada \$22.50).

## LIGHT EXPERIMENTS

No. 6516

With an outfit of Gilbert Light Experiments you can have some wonderful fun. So many things that are entirely different from the things you have been satisfied with until now. There's a big book on light with every outfit telling interesting facts about the sun and the sun's rays, and how to make use of them. Then, too, it tells you how to give shadow shows, give an exhibition of freakish images that will amuse your friends.

While you are playing with this outfit, you will learn about the telescope, opera glasses, microscope, moving picture machine, and many other important instruments. You will learn too, why eyeglasses improve the sight and why a lens produces an upright image or an inverted one. There's a pile of fun in every one of these outfits for a boy. It is complete with lens, prisms, mirrors, and all necessary equipment. Packed in Gilbert Toy carton, with four color label, size  $18 \times 10 \times 1\frac{1}{4}$  inches. Approximate weight: 2 lbs. Price \$10.00 (Canada \$15.00).



## SOUND EXPERIMENTS

No. 6521

Do you know that hearing is just feeling with the ear? That in reality the thing we call sound, which we think of as a noise or as a musical note, is just an impression on the brain? Very few boys know this, and if you would like to be one of the few that do, you surely want an outfit of Gilbert Sound Experiments.



With one of these outfits you can find out just what sound is — how it is produced — why some pianos sound better than others, — why a violin produces a musical tone, and many other things, including a number of startling table rapping tricks with which you can astonish your friends. The outfit contains tuning forks and sound box, receivers, mallet, etc., and big book on sound, telling how to perform many fascinating experiments with the apparatus in the set, and also shows you how to do many startling tricks with apparatus you have in your own home. This is one of the most intensely interesting scientific toys of today and every boy should have one. Packed in New Gilbert Toy carton with four color label, size  $18 \times 10 \times 1\frac{1}{4}$  inches. Approximate weight: 2 lbs., 12 ozs. Price \$7.50 (Canada \$11.25).

## MAGNETIC FUN AND FACTS

Did it ever seem strange to you that a compass always points to the North? Do you know why it does — what it is that attracts the fine needle point of the compass? Very few boys do. The boys who do not are the boys who have never heard of magnetism and do not realize what a tremendous effect it has on our everyday life.

Gilbert Magnetic Fun and Facts explain all about the compass and many other things besides. They show you how to build a simple magnetic motor, a corking little electric shocker, a magnetic tight rope walker, magnetic jack straws, a magnetic navy and any number of electrical tricks with which you can surprise your friends. You'll like these outfits and the big book which comes with them telling you many things about electricity and magnetism you never dreamed of.

### No. 6504 (Not illustrated)

Contains two horse-shoe magnets, iron filings and other parts for performing many of the experiments illustrated in the big book on magnetism included with the set. Comes in Gilbert Toy carton, with four color label, size  $12\frac{1}{4} \times 8\frac{3}{4} \times 1\frac{1}{4}$  inches. Price \$1.00 (Canada \$1.50).

### No. 6506

Contains parts for building simple magnetic motor, iron filings, etc., for performing experiments in big book of instructions, also included.

Packed in Gilbert Toy carton with four color label, size  $8\frac{3}{4} \times 12\frac{1}{4} \times 1\frac{1}{4}$  inches. Approximate weight: 2 lbs. Price \$3.75 (Canada \$5.65).

### No. 6507 (Not illustrated)

Contains all parts for building simple magnetic motor, iron filings, etc., and also parts for building electric generator or shocker. Authoritative book on magnetism included with the set explains in detail a number of instructive experiments that can be performed.

Comes in stained hardwood cabinet, size  $12\frac{1}{4} \times 8\frac{3}{4} \times 2$  inches. Approximate weight: 3 lbs., 9 ozs. Price \$10.00 (Canada \$15.00).



## WEATHER BUREAU SETS

In the minds of most people a very silly idea prevails about the weather and the weather man. It is the general idea that the weather knows no laws — that it is lawless and reckless, fickle and changeable; that the weather man is a sort of conjurer, and by some mysterious gift he is able to prophecy things that most people know nothing about. Nothing could be further from the truth. The study of the weather is a science, like electricity, chemistry, or medicine; there is nothing mysterious about it at all.



As a matter of fact, the weather man is a scientist, and by means of his instruments which indicate definite things to him, he comes to certain conclusions. He is not a prophet; he does not prophesy, he forecasts. He has a weather bureau station which is maintained by the Government. There are over a hundred of these stations located in various cities throughout the United States, and they are very interesting places. They are usually located on the top floor of one of the tallest buildings in the city, with apparatus on the roof, some of it electrically connected in the room below with wonderful machines which make records all day long on special charts.

If you are interested in having a weather bureau station of your own, I can tell you now that it will be one of the most interesting things you ever had in your life. You will have a knowledge of a subject on which most people are quite ignorant, and if you are a boy you will stand for leadership among boys for knowing about things that to most people are mysterious and magical

### No. 6533

This outfit enables you to study the first principles of the weather. It contains an anemometer for determining the velocity of the wind; a wind vane for wind direction as well as thermometers by which you can find out the humidity in the air, etc. A dandy boy's book on weather explains all about how to set up the outfit and operate it.

Comes in Gilbert Toy carton with four color label, size  $18 \times 10 \times 2\frac{1}{4}$  inches. Approximate weight: 1 lb., 12 ozs. Price \$5.00 (Canada \$7.50).



## No. 6534



A more advanced outfit than our No. 6533. In addition to the weather vane, anemometer, etc., it contains a very high grade barometer so you can find out more about the science of weather and do a number of interesting experiments. There is also an electrical apparatus to be connected to the anemometer, simplifying the studying of the wind velocity considerably. The 150 page book on weather also included will be found intensely interesting.

Packed in Gilbert Toy carton with four color label, size 18 x 10 x 2 1/4 inches. Approximate weight: 2 lbs., 4 ozs. Price \$12.50 (Canada \$18.75).

## No. 6538

The most complete weather bureau outfit we make. It contains the apparatus in our No. 6534 set and in addition a maximum and minimum thermometer, and a special "Sunshine Recorder." With this outfit, you can do all of the experiments explained in our 150 page book on weather.



This is a very attractive and interesting book, written particularly for boys and contains some 150 illustrations. With this book and the apparatus in the set you can have a very complete weather bureau of your own and make accurate forecasts of the weather.

Comes in stained hardwood cabinet fitted with strap hinges and suit case clasps, size 20 x 12 x 3 3/4 in. Approximate weight: 8 lbs., 8 ozs. Price \$27.50 (Canada \$41.25).

## GLASS BLOWING

## No. 6545

Here's an entirely new outfit that I believe will soon become one of the most popular of all Gilbert Toys. Glass Blowing is a science ages old, but still very little understood. It's one of those things we have become so accustomed to that we never stop to realize that it is really wonderful.

You can have all kinds of fun with this set making many attractive and useful articles for yourself — besides it will be a big help to you if you have the Gilbert Hydraulic and Pneumatic Engineering Outfit, Chemistry, etc.

It contains glass tubing in various lengths, blow pipe, alcohol lamp and complete apparatus for performing a number of experiments illustrated and described in the big book on glass blowing written by Prof. C. J. Linde of MacDonal University, Quebec.

Packed in Gilbert Toy carton with four color label size, 18 x 10 x 1 1/4". Approximate weight: 2 lbs. Price \$5.00 (Canada \$7.50).



## MINERALOGY

## No. 6550

Do you know what coal is? Do you know how it is mined? Where they get diamonds? How to tell a good one? If you'd like to know these things and lots of others just as interesting, you surely want one of these new Gilbert Outfits on Mineralogy. It comprises a complete assortment of minerals and metals for you to practice with, as well as a boy's book on Mineralogy, prepared by Mr. William J. Horn, our Research Chemist. There are many fascinating experiments included that you will surely be pleased with.



Packed in Gilbert Toy carton with four color label, size 18 x 10 x 1 1/4". Approximate weight: 1 lb., 9 ozs. Price \$7.50 (Canada \$11.25).

## CHEMISTRY



### No. 5002

This set on chemistry consists of simple solutions that are entirely harmless. Nothing ought to interest you so much as making the wet cell battery you can make with this set. This is needed very much to produce electricity for different purposes. The instructions tell you in plain language how to use the material you have. Packed in Gilbert Toy carton, size  $12\frac{1}{4} \times 8\frac{3}{4} \times 1\frac{1}{4}$  inches. Approximate weight: 1 lb. Price \$1.50 (Canada \$2.25).



### No. 5007

Of all the big sciences there are two which I think are the most interesting. One is Electricity, which I told you about, the other is Chemistry — and the two sciences are worked together in a great many cases. If you know Chemistry, you will know how a great many of the things which are so necessary to your every day life, are manufactured or grown. Chemistry tells you how dye is made for the clothes you wear. What the substance you call "lead" in the pencil you are writing with really is. How soap is made. How your mother's silver-ware is plated — and any number of interesting things like that. Wouldn't you like to be able to make ammonia for your mother — or a bar of soap — do chemical magic tricks — or make a wet cell battery to operate your door bell? You can do these things with Gilbert chemistry outfits.

Remember these are all entirely new sets that are certainly great ones. They are chock full of wooden boxes with some of the salts and chemicals, and glass bottles sealed with wax, for the liquids.



With the harmless solutions that come in this set you can prepare many substances used in every day life. Produce startling effects by placing one ingredient with another. Learn the method of making cloth fire-proof. How to pass an egg through the neck of a bottle and manufacture disappearing ink. Packed in the Gilbert Toy carton, with four color label, size  $8\frac{3}{4} \times 12\frac{1}{4} \times 1\frac{1}{4}$  inches. Approximate weight: 1 lb. Price, \$2.50 (Canada \$3.75).

### No. 5008

With this set you can find out how dye is made for the clothes you wear; what the substance you call "lead" in the pencil you are writing with, really is; how soap is made; how your mother's silver-ware is plated — and any number of interesting things like that. Here's a corking chemistry outfit. In addition to the many acids and alkalis included, this outfit has a test tube rack, filter paper, alcohol lamps, etc. Book of Instructions gives complete directions for the many experiments you can do with this set. Packed in Gilbert Toy carton with four color label, size  $18 \times 10 \times 1\frac{1}{4}$  inches. Approximate weight: 1 lb., 10 ozs. Price \$5.00 (Canada \$7.50).



### No. 5010

With a set of this size — the largest in the Chemistry Outfits — you can learn the elementary facts of this science and make your play both fascinating and beneficial. Do electro-typing — make tests of metals. It will be a very easy matter for you to plate old metals, etc., with a finish resembling gold. All this is explained in a book of instructions which covers every detail and is included in each set. There are a great many tricks that you can do with your solutions. With this larger set you can do many of them. Packed in hardwood cabinet, this set is very convenient to carry about. Size,  $18\frac{3}{4} \times 10\frac{3}{4} \times 3$  inches. Approximate weight: 6 lbs., 8 ozs. Price \$15.00 (Canada \$22.50).



### No. 5009

Here's a Chemistry set you will be proud of. It is a complete chemical laboratory in itself, packed full of harmless chemicals of all kinds, as well as test tubes, funnel, glass tubes, alcohol lamp, filter paper and many other things to perform the hundreds of experiments told about in the big book that comes with the set. It all comes in great big stained hardwood cabinet, size  $22 \times 8\frac{1}{2} \times 3\frac{1}{4}$  inches. Approximate weight: 5 lbs., 8 ozs. Price \$8.75 (Canada \$13.15).

## CARPENTER'S OUTFIT

## No. 701

Contains just the number of tools you want to make useful articles with. An apron is included, too, one that you can put on when you start working. This has pockets in it to hold the tools. Everything is right where you need it, saw, hammer, screw driver, triangle, etc. With this set you will see how simple it is to make models and useful things for the house and for your room. There's no end to the things you can build — book racks, flower stands, shelves, etc. Gilbert Carpentry Outfit is a handy set for any boy to own. Packed in Gilbert Toy carton, 18 x 10 x 1 1/4 inches. Weight, 2 lbs., 4 ozs. Price \$2.50 (Canada \$3.75).



## CARPENTRY SETS

These chests contain practical tools most used by boys. They are splendid values, packed in stained wooden chests, some of them with special compartments for nails, screws, nuts, bolts, etc.

With each outfit comes an authoritative book — a complete treatise on manual training from the correct use of tools to working drawings of a number of useful articles that can be built for the home, garage, etc.

## No. 703

- |              |                  |
|--------------|------------------|
| 1 Mitre Box  | 1 Carpentry Book |
| 1 Try Square | 1 Hammer         |
| 1 Awl        | 1 Brace          |
| 1 Saw        | 1 Bit            |

Cabinet natural wood finish, size 22 x 8 1/2 x 3 inches with compartments for nails, screws, nuts, etc. Approximate weight 7 lbs. Price \$2.50 (Canada \$3.75).

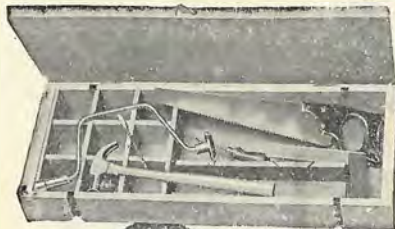

## No. 711

- |                  |                |
|------------------|----------------|
| 1 Vise           | 1 Screw Driver |
| 1 Mitre Box      | 1 Hammer       |
| 1 Try Square     | 1 Brace        |
| 1 Awl            | 1 Bit          |
| 1 Saw            | 1 12" Rule     |
| 1 Carpentry Book | 1 Chisel       |

Cabinet:—Stained wood, size 22 x 8 1/2 x 5 1/2 inches with compartments for nails, tacks, bolts, nuts, screws, etc. Approximate weight, 9 1/4 lbs. Price \$5.00 (Canada \$7.50).



## No. 721

- |                    |                  |
|--------------------|------------------|
| 1 Steel Try Square | 1 Nail Set       |
| 1 Saw              | 1 Carpentry Book |
| 1 Hammer           | 1 2 ft. Rule     |
| 1 Brace            | 1 Plane          |
| 2 Chisels          | 1 Awl            |
| 2 Bits             | 1 Screw Driver   |
| 1 Gimlet Bit       | 1 Scroll Saw     |

Cabinet:—Stained wood fitted with strap hinges and suit case catches, size 22 x 8 1/2 x 5 1/2 inches, with compartments for nails, screws, bolts, nuts, etc. Approximate Weight, 8 lbs., 8 ozs. Price \$10.00 (Canada \$15.00).



## No. 726

- |                    |                  |
|--------------------|------------------|
| 1 Gimlet Bit       | 1 Screw Driver   |
| 2 Bits             | 1 Carpentry Book |
| 3 Chisels          | 1 Scroll Saw     |
| 1 Nail Set         | 1 Saw            |
| 1 Steel Try Square | 1 Plane          |
| 1 Awl              | 1 Hammer         |
| 1 Draw Shave       | 1 Brace          |
| 1 Pliers           |                  |

Cabinet:—Special compact chest, stained wood, fitted with strap hinges and suit case catches, size 16 3/4 x 10 1/2 x 3 1/2 inches. Approximate weight, 7 lbs. Price \$13.50 (Canada \$20.25).



## No. 736

- |                    |                  |
|--------------------|------------------|
| 1 Screw Driver     | 1 Brace          |
| 1 Hammer           | 1 Saw            |
| 1 2 ft. Rule       | 1 Carpentry Book |
| 2 Bits             | 1 Plane          |
| 1 Gimlet Bit       | 1 Scroll Saw     |
| 1 Nail Set         | 1 Pliers         |
| 1 Awl              | 1 Draw Shave     |
| 1 Steel Try Square | 3 Chisels        |

Cabinet:—Special compact Chest, stained wood, fitted with strap hinges and suit case catches, size 18 3/4 x 10 3/4 x 3 1/2 inches. Approximate weight 9 lbs. Price \$18.50 (Canada \$27.75).



## No. 741

- |                    |                       |
|--------------------|-----------------------|
| 1 Awl              | 1 Hammer              |
| 1 Brace            | 1 Draw Shave          |
| 1 Plane            | 3 Chisels             |
| 1 Gimlet Bit       | 1 Screw Driver        |
| 1 Nail Set         | 1 Saw Set with handle |
| 4 Bits             | and 3 Saws            |
| 1 Rule             | 1 Carpentry Book      |
| 1 Steel Try Square |                       |

Cabinet:—Stained hardwood, fitted with suit case clasps and strap hinges, size 20 x 12 x 3 1/4 inches. Approximate Weight, 11 lbs. 8 ozs. Price \$28.00 (Canada \$42.00).



**No. 750**

- |                 |                                  |
|-----------------|----------------------------------|
| 1 Nail Set      | 1 Rule                           |
| 1 Brace         | 1 Plane                          |
| 1 Countersink   | 1 Combination Set of Tools       |
| 2 Screw Drivers | 1 Try Square                     |
| 7 Bits          | 2 Hammers                        |
| 1 Gimlet Bit    | 1 Saw Set with handle and 3 Saws |
| 1 Glass Cutter  | 1 Carpentry Book                 |
| 1 Draw Shave    |                                  |
| 3 Chisels       |                                  |
| 1 Pliers        |                                  |

Cabinet:—Stained hardwood, fitted with suit case clasps and brass corners, size 21 x 14 x 4 inches. Approximate weight, 18 lbs., 8 ozs. Price \$45.00 (Canada \$67.50).

These two chests are special chests of which we have only a limited supply. The chests themselves are beautifully stained and polished hardwood, size 20½ x 12¾ x 10 inches fitted with heavy brass hinges and lock, and with tray for nails, small tools, etc. These chests were originally bought by the U. S. Government for use of General Pershing's American Expeditionary Forces and were made up to U. S. Government standards. We were able to secure a quantity of them at the close of the war and have fitted them with a supply of the best quality tools. These chests will be an ornament to any workshop.

**No. 755**

(Not Illustrated)

- |                   |                  |              |
|-------------------|------------------|--------------|
| 1 Nail Set        | 3 Chisels        | 1 Mitre Box  |
| 1 Wire Brace      | 1 Awl            | 1 Scroll Saw |
| 1 Gimlet Bit      | 1 Pliers         | 1 Plane      |
| 3 Bits            | 1 Screw Driver   | 1 Try Square |
| 1 Rule            | 1 Carpentry Book | 1 Hammer     |
| 1 Soldering Iron  | 2 Saws           |              |
| 1 Soldering Paste | 1 Bench Vice     |              |

Cabinet:—Special Pershing Expeditionary Force cypress chest, varnished oak finish, size 20½ x 12¾ x 10 inches. Approximate Weight, 24 lbs. Price \$25.00 (Canada \$37.50).

**No. 760**

- |                |                                  |
|----------------|----------------------------------|
| 1 Plane        | 1 Soldering Iron                 |
| 1 Try Square   | 1 Soldering Paste                |
| 2 Hammers      | 1 Countersink                    |
| 1 Brace        | 1 Combination Set of Tools       |
| 4 Bits         | 1 Bench Vice                     |
| 1 Rule         | 1 Gimlet Bit                     |
| 3 Chisels      | 1 Back Saw                       |
| 1 Draw Shave   | 1 Scroll Saw                     |
| 1 Mitre Box    | 1 Saw Set with handle and 3 Saws |
| 1 Screw Driver | 1 Carpentry Book                 |
| 1 Pliers       |                                  |
| 1 Nail Set     |                                  |

Cabinet:—Special Pershing Expeditionary Force cypress chest, varnished oak finish, size 20½ x 12¾ x 10 inches. Approximate weight, 31 lbs. Price \$50.00 (Canada \$75.00).



## DESIGNER AND TOY MAKER

**No. 8001**

Learn how to enlarge or reduce different designs with this set. You will be interested in the animal puzzles printed on the top of the reducing and enlarging apparatus. The idea of that is to trace with the stylus one of the animals. If you have followed the correct lines, you will find a small reproduction that your pencil has made. The animal puzzle is just something for you to start on. After you know how to use the set you can use any design you want — transfer it to wood and then saw it out with the scroll saw included in this set. You can build easily bird cages, small book racks and a number of useful articles. Packed in Gilbert Toy carton, size 12½ x 8¾ x 1¼ inches. Approximate weight, 1 lb. Price \$1.00 (Canada \$1.50). \$1.50.

**No. 8002**

This larger Designer and Toy Maker Outfit gives you complete material for making exact copies of designs found in magazines and books. You can either reduce or increase the size of the article you build from the original sketch as you prefer. There is included also a board on which you can try out your designs. After your pattern is made, you can use the colors that come in this set to paint it with very pretty effects. Comes in Gilbert Toy carton, size 18 x 10 x 1¼ inches. Approximate weight, 1 lb., 8 ozs. Price \$2.50 (Canada \$3.75).



## PICTURE FRAMING

**No. 703**

In times past, the framing of pictures was always considered a job for the art stores to handle. It certainly is true that picture framing properly done is an art; but it is an art which need not be left to the stores — that is, to professionals. With the simple, well-chosen tools in this set, a small bench or table upon which to work, and a little careful study, you will be able to design and build your picture frames and build them right — frames which will add beauty and dignity to your favorite enlargements, color prints, etc.

There's a whole heap of fun in this set. Every set contains layout board, mitre box and saw, hammer, etc., together with strips of moulding to practice with. There's also a book of instructions telling you just how to frame pictures. Packed in Gilbert Toy carton, size 18 x 10 x 2¼ inches. Approximate Weight, 5 lbs., 12 ozs. Price \$7.50 (Canada \$11.25).



## SOLDERING OUTFITS

These new soldering outfits are really more than toys. They are mighty handy things to have around the house if any of your Mother's pans or small kettles spring a leak. With one of these outfits on hand you can quickly repair them.

### No. 7001

This outfit contains soldering iron, solder, lamp, flux, sheets of metal and complete book on soldering. Packed in Gilbert Toy carton, size  $12\frac{1}{4} \times 8\frac{3}{4} \times 1\frac{1}{4}$  inches. Approximate Weight, 1 lb. Price, \$1.00 (Canada \$1.50).



$1\frac{1}{4}$  inches. Approximate Weight, 1 lb. Price, \$1.00 (Canada \$1.50).

### No. 7002

This outfit contains a dandy little oven which can be used with gas or regular lamp in addition to soldering iron, solder, lamp, flux, sheets of metal and big book on soldering. Packed in Gilbert Toy carton, size  $12\frac{1}{4} \times 8\frac{3}{4} \times 2$  inches. Approximate Weight, 2 lbs. Price \$2.50 (Canada \$3.75).



## TIN CAN TOYS

The idea of making toys and handy articles from tin cans seems queer because you have always looked upon them as worthless. You cannot realize what interesting models will result from a little work on cans. Automobiles, power boats, tug boats and numerous other toys can be made. You can make, too, handy articles for the house, such as ash trays, biscuit cutters, etc.

### No. 7052

The set contains a complete soldering outfit, mallet, soldering iron, shears and forming blocks and book of instructions. Packed in Gilbert Toy carton, size  $18 \times 10 \times 1\frac{1}{4}$  inches. Approximate weight, 3 lbs., 8 ozs. Price \$5.00 (Canada \$7.50).



### No. 7053

The boy who wants a complete outfit will be interested in this, as it contains full size tools, such as a boy needs, with which to make big models. A book containing many illustrations and detailed instructions for making toys was prepared by Mr. Thatcher, the inventor. Comes packed in stained hardwood cabinet, size  $22 \times 8\frac{1}{2} \times 2\frac{1}{2}$  in. Approximate Weight, 6 lbs., 11 ozs. Price \$10.00 (Canada \$15.00).



## BRIK-TOR

### "The Toy for Young Architects"

Here's just the toy that all boys who own construction toys have been waiting for — a toy that enables you to complete your models so they look real.

Haven't you often wished that you could add the foundation, brick walls, roofs, windows, etc., to the framework models you build, in a way that would make them look true to life?

Well! You can do it with Brik-tor. You will now be able to build whole cities, add foundation walls, roofs to your buildings, bridges, etc., with steel bricks in many strikingly beautiful color combinations, and you will be able to put in the windows, too, and streets, side-walks and piers — everything! There are two outfits:

### No. A (Not Illustrated)

In the Gilbert Toy carton,  $12\frac{1}{4} \times 8\frac{3}{4} \times 1\frac{1}{4}$  inches. Approximate weight: 1 lb., 2 ozs. Price \$1.50 (Canada \$2.25).

### No. C

Packed in cardboard carton, size  $12\frac{1}{4} \times 8\frac{3}{4} \times 2\frac{1}{4}$  inches. Approximate weight: 6 lbs., 7 ozs. Price \$5.00 (Canada \$7.50).



## MACHINE DESIGN

### No. 6535

Wouldn't you like to have an equipment which you could set up in your own home and have it operate just like the big machines do?

Gilbert Machine Design is knocked down machinery, in miniature. If you are interested in mechanics you will be pleased with this set. There will be any amount of fun for you putting axles in place and connecting them with rods. Then when your machine is complete you can make it go exactly in the same way as the big machines do in factories. The parts are made of cast iron with nickel plate finish. You can be sure that your machinery is strong-ly built and will last a long time.

With the set comes a book of instructions which explains the different types of machines and the work each one does. Packed in stained hardwood cabinet,  $20 \times 12 \times 3\frac{1}{4}$  inches. Approximate weight: 8 lbs. Price \$10.50 (Canada \$15.75).

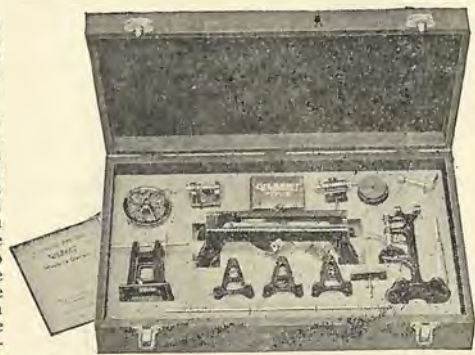

## GILBERT TOY MOTORS

You know that unless a motor works when you want it to, it is more trouble than it's worth. And I can tell you, boys, these Gilbert Toy Motors work. They are strong and powerful and will surprise you with the way they stand up. Of course, besides motors, I make lots of electrical toys to be used with them, such as control switches, reverse bases, transformers and electric shockers. But you can be sure you can depend on all of them to do the things you want to have them do. They are great to use with your Erector Models. Your regular toy dealer sells them.



**P-52 Motor.** A dandy two terminal motor for operating light running models. Operates on either batteries or from transformer. Height,  $3\frac{3}{4}$ ". Approximate weight: 8 ozs. Price \$1.50 (Canada \$2.25).

**P-53 Motor.** This motor has two terminals, pressed steel base, latest type tubular holders with copper gauze brushes. Works great. Height,  $3\frac{3}{4}$ ". Weight 14 ozs. Price \$2.25 (Canada \$3.40).



**P-54 Motor.** This is the same as P-53 Motor mounted on a reverse base, so that you can run it either backwards or forwards. Fine for running elevator models. Height  $3\frac{3}{4}$ ". Weight 14 ozs. Price \$2.50 (Canada \$3.75).



**P-56C Motor.** This is one of the strongest universal toy motors made. Attaches direct to electric light socket, operating on alternating or direct current 110 volts. Made of cast iron with bearings an integral part of casting. Height,  $3\frac{7}{8}$ ". Weight 3 lbs. Price \$5.00 (Canada \$7.50).



**P-58 Four Terminal Motor.** I made this motor especially for operating Erector and other Mechanical Toy models. Can be used with P-59 Reverse Base or P-61 Control Switch. You won't find a better motor for the price anywhere. Height,  $2\frac{3}{4}$ ". Weight, 12 ozs. Price \$2.25 (Canada \$3.40).

**P-59 Reverse Base.** This is used to operate four terminal toy motors either backward or forward. Can be directly attached to motor P-58 or at a distance with longer wire. Size, 4 x 4". Weight 7 ozs. Price \$1.00 (Canada \$1.50).



**P-73B Motor.** Cast iron motor shell and base. Looks very much like big commercial motors. Can be used on batteries or from house current through a transformer. Height  $4\frac{3}{4}$ ". Weight 3 lbs. Price \$2.50 (Canada \$3.75).



**P-82 Battery Wound Motor.** This motor is meant especially to be used with batteries. Has die cast frame and cast iron base. Height  $3\frac{7}{8}$ ". Weight, 2 lbs. Price \$5.00, (Canada \$7.50).

**B-685 Universal Motor.** This is more than a toy. It's a real motor of  $1/50$  horse-power. The same motor I use to run all my big toy machine shops. Die cast frame. Cast base similar to base on P-56C. Has cord and plug ready to attach to any lamp socket. Height 5". Weight, 2 lbs., 8 ozs. Price \$8.50 (Canada \$12.75).



**P-61C Control Switch.** With this control switch you can regulate the speed of your motor. It is controlled by lever, just like all big rheostats. Porcelain base, size 4 x 4". Weight, 7 ozs. Price \$1.00 (Canada \$1.50).

**P-65 Motor.** This is a splendid two terminal motor to be operated on batteries. Equipped with two handles so that it may also be operated as electric shocker. Height,  $3\frac{3}{4}$ ". Weight, 14 ozs. Price \$2.50 (Canada \$3.75).



**275 Electrical Shocker.** Here's an electrical toy you can have loads of fun with. Get your friends to hold the handles and give them a real electric shock. Size, 4 x  $2\frac{3}{4}$ ". Weight, 2 lbs., 8 ozs. Price \$2.50 (Canada \$3.75).

**P-60C Transformer.** This transformer saves the use of batteries. Attach it to your electric light socket (alternating current only) and run your motor direct from it. Comes with 5 ft. cord and plug. Size,  $3\frac{1}{2}$  x  $3\frac{3}{4}$  x  $2\frac{1}{2}$ ". Weight: 2 lbs., 12 ozs. Price \$6.50 (Canada \$9.75).



## ANCHOR BLOCKS

Here you are boys, real stone building blocks with which you can build miniature models of houses, bridges, churches, city halls and many other things. Best of all, the stones and bricks are designed just like the big stones that are used to make real buildings. Your models will look true to life and dandy reproductions of all kinds of architecture. Each outfit contains an assortment of stones in many sizes, shapes and colors. Some of the outfits contain stones only for building churches, houses, garages, fire engine houses, city halls, libraries, and any number of those kind of buildings, while other outfits contain the famous Erector parts for building bridges, tunnels and engineering models of that kind. The Erector parts, you can also use as foundations for sky-scrapers, towers, wells, etc.

With every outfit comes a finely illustrated design book printed in colors and showing many models that have already been built with Gilbert Anchor Blocks. You can, of course, build many models not shown in the book that you think of yourself.

### No. 1

Contains Stones and Erector Parts.  
Box:—New Gilbert Toy carton with four color label, size  $9\frac{1}{2} \times 7 \times 1\frac{1}{4}$ ". Approximate Weight: 3 lbs., 8 ozs. Price \$1.00 (Canada \$1.50).



### No. 2

Contains Stones.  
Box:—New Gilbert Toy carton with four color label, size  $12\frac{1}{4} \times 8\frac{3}{4} \times 1\frac{1}{4}$ ". Approximate Weight: 6 lbs., 6 ozs. Price \$2.50 (Canada \$3.75).



### No. 3

Contains Stones and Erector Parts.  
Box:—Stained hardwood cabinet, size  $12\frac{1}{4} \times 8\frac{1}{2} \times 1\frac{3}{4}$ ". Approximate Weight, 5 lbs. Price, \$3.50 (Canada \$5.25).



### No. 4

Contains Stones.  
Box:—Stained hardwood cabinet, size  $12\frac{1}{4} \times 8\frac{1}{2} \times 1\frac{3}{4}$ ". Approximate Weight, 6 lbs. Price \$3.50 (Canada \$5.25).

### No. 5

Contains Stones and Erector Parts.  
Box:—Stained hardwood cabinet, size  $12\frac{1}{4} \times 8\frac{3}{4} \times 3$ ". Approximate Weight, 8 lbs., 10 ozs. Price, \$5.00 (Canada \$7.50).

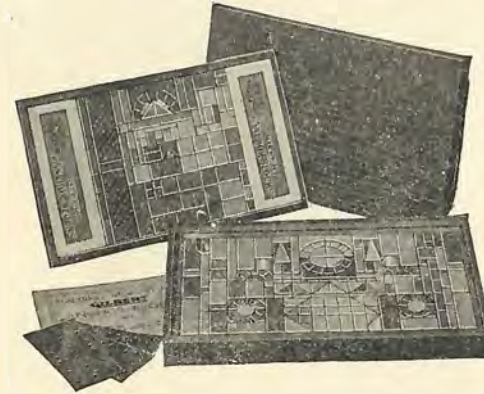

### No. 6

Contains Stones.  
Box:—Stained hardwood cabinet, size  $12\frac{1}{4} \times 8\frac{3}{4} \times 3$ ". Approximate weight, 10 lbs., 4 ozs. Price \$6.00 (Canada \$9.00).

### No. 7

Contains Stones and Erector Parts.  
Box:—Stained hardwood cabinet, size  $16\frac{1}{2} \times 10 \times 3$ ". Approximate Weight, 16 lbs., 10 ozs. Price \$10.00 (Canada \$15.00).

### No. 8

Contains Stones.  
Box:—Stained hardwood cabinet, size  $16\frac{1}{2} \times 10 \times 3$ ". Approximate Weight, 16 lbs., 12 ozs. Price, \$10.00 (Canada \$15.00).

### No. 9

Contains Stones and Erector Parts.  
Box:—Stained hardwood cabinet, size  $18\frac{3}{4} \times 10\frac{3}{4} \times 3$ ". Approximate Weight. 23 lbs., 8 ozs. Price \$15.00 (Canada \$22.50).

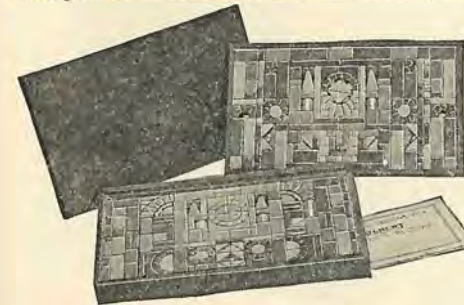

### No. 10

Contains Stones.  
Box:— Stained hardwood cabinet, size  $18\frac{3}{4} \times 10\frac{3}{4} \times 3$ ". Approximate Weight, 24 lbs., 6 ozs. Price \$15.00 (Canada \$22.50).

## MYSTO MAGIC

As you boys probably know, I first started this big Gilbert Toy business by making Magic tricks, but long before that I was practicing Magic professionally, giving entertainments for lodges, clubs, churches and other organizations, and in this way earned practically my entire expenses for college. For this reason I am in a very good position to appreciate what it means to boys to have something of this kind that they can fall back upon. Something that will help them work their way through school, or give them additional spending money. By no means is it the money alone that you derive from this that makes it enjoyable. It's one of the greatest ways to amuse yourself and your friends that I know of. Best of all, it trains your eyes, fingers and hands. You probably don't believe that, but after you have practiced Magic for a while you'll soon see that it is entirely true.



### No. 2001

Contains Multiplying Billiard Balls, Cigarette Vanisher, Disappearing Coins and many others. The Magic Wand and show poster come with this outfit. Also a big book of instructions telling just how to do each trick.

Packed in Gilbert Toy carton, 12¼ x 8¾ x 1¼ inches. Weight Approximately 1 lb. Price \$1.50 (Canada \$2.25).

### No. 2003

A magic outfit somewhat larger than No. 2001, and containing more tricks. In addition to those in No. 2001, this set contains the Passe Passe Coin Trick, Chinese Linking Rings and a number of other tricks. The big book of instructions included tells how to hold your hands while performing, and also explains how to do some marvelous tricks, the same as performed on the stage. Packed in Gilbert Toy carton, size 12¼ x 8¾ x 1¼ inches. Weight Approximately 1 lb. Price \$2.50 (Canada \$3.75).



### No. 2005

Just think of the fun you can have making dollar bills appear in your coat sleeve or making cigarettes and handkerchiefs vanish. This outfit contains a very good assortment of famous tricks, like the Drumhead Tube, Linking Rings, Handkerchief Cassette and many others. The book of instructions tells you how to perform each trick and lists many you can do with apparatus you have in your own home. Packed in Gilbert Toy carton size 18 x 10 x 1¼". Weight approximately 1 lb., 8 ozs. Price \$5.00 (Canada \$7.50).



### No. 2006

One of the best collections of amateur magic for giving complete entertainments; containing Magician's Nickel-Tipped Wand, Show Poster, and illustrated Manual giving complete instructions how to give a performance, including "patter," etc. Some of the tricks included are: Spirit Slate, Siberian Transport Chain, Drumhead Tube, Handkerchief Cassette, Passé-Passe Coin Trick, etc.



Comes in stained hardwood cabinet with tray, size 13 x 9 x 3 inches. Approximate Weight: 6 lbs. Price \$7.50. (Canada \$11.25).

## PROFESSIONAL SETS

The two outfits following are really semi-professional sets. They are among the best collections of amateur magic and intended for the boy who, after practicing Magic for some time, desires to equip himself with an outfit he can use to give shows, not only to his friends, but for church, lodges, and Y. M. C. A.'s as well. They contain a splendid assortment of the leading tricks that are practiced by the foremost magicians today.

### No. 2009

Contains:—Large Wand, Show Poster, Phantom Card Trick, Vanishing Coin from Glass, Drumhead Tube, Magic Slates, Phantom Ring, Ching Ling Soo, Okeito Coin Box, Mysto Coin Shells, Disappearing Handkerchief, Princess Card Trick, Pick-it-Out, Sphinx, Papel Blanco, Rice to Water, Chinese Linking Rings, Cigarette Vanisher, etc.

Box:—Stained hardwood compact chest with suit case clasps, size  $16\frac{3}{4} \times 10\frac{1}{4} \times 2\frac{3}{4}$  inches. Approximate Weight, 4 lbs., 12 ozs. Price \$10.00 (Canada \$15.00).



### No. 2010

Contains:—Large Wand, Show Poster, Papel Blanco, Horse-hair Coin, Kellar Coffee and Milk, Magic Slates, Drumhead Tubes, Large Billiard Balls, White Handkerchief, Yellow Handkerchief, Red Handkerchief, Blue Handkerchief, Purple Handkerchief, Sphinx, Princess, Mysto Coins, Handkerchief Fake, Ching Ling Soo, Coin Shells, etc., as well as complete book of instructions.

Box:—Stained hardwood cabinet, with partitions for separate tricks, size  $22 \times 8\frac{1}{2} \times 5\frac{1}{2}$  in. Approximate Weight, 8 lbs., 12 ozs. Price \$25.00 (Canada \$37.50).

## CARD TRICKS

### No. 2007

Boys, when you have watched magicians perform their mystifying card tricks, haven't you had the desire to perform those very same stunts yourself?

It is great sport, and you can easily become masters in this line of entertainment by closely following directions given in the Book of Instructions which comes with every Gilbert Magic Card Trick Outfit.

In addition to the Magician's pack of cards, with which can be performed a great number of tricks, are eight

other mysterious card stunts that are used by the foremost magicians. Set packed in Gilbert Toy carton, size  $12\frac{1}{4} \times 8\frac{3}{4} \times 1\frac{1}{4}$ ". Approximate weight: 1 lb. Price \$2.00 (Canada \$3.00).



## COIN TRICKS

### No. 2020

Just think! You can give shows and mystify your friends with the same fascinating coin tricks that are used on the stage today by many of the professional magicians.

You can make a coin vanish from a newspaper—vanish a coin from your closed hand—make coins appear out of the air—pass a coin through a table—vanish a coin from a glass, and many other tricks that will make your friends' eyes open in wonder.

With a Gilbert Coin Trick Outfit all of these things are simple. There is a big book comes with each set explaining how each trick is performed, just how to hold your hands when giving shows on the stage, how to talk so that you will divert the attention of your audience, in fact all the information you need to give Magic Coin Trick entertainments.

The Outfit contains a complete assortment of magic coins. Packed in Gilbert Toy carton, size  $18 \times 10 \times 1\frac{1}{4}$  inches. Price \$2.50 (Canada \$3.75).



## KNOTS AND SPLICES

### No. 2021

They thought the rope was tied tightly and in a way that would make it impossible for you to escape. From all appearances they were right, but they did not know that for you it was a very easy matter to escape. You had an outfit of Gilbert Knots and Splices from which you had learned how to make various kinds of rope ties, and how to get out of them. There was hardly a knot that any one could show you that you wouldn't know how to tie and untie.

If you haven't already one of these sets, you certainly want to

get one, for with it you will learn how to splice rope; how to tie useful knots; and how to do many tricks that are now being performed on the stage by famous magicians. You can give shows for your church or club.

Outfit contains a complete assortment of sample knots, with a quantity of rope to practice with, as well as complete book on knots, telling how to tie them or how to perform many startling experiments. Packed in the Gilbert Toy carton,  $18 \times 10 \times 1\frac{1}{4}$  inches. Price \$1.00 (Canada \$1.50).



## CHEMICAL MAGIC

No. 2022



How do you suppose magicians on the stage pour red, then white and then blue liquids all from the same pitcher right before your eyes? Haven't you envied them and wished you could do wonderful tricks of that kind? It really isn't as hard as it looks, once you know how, and a Gilbert Chemical Magic Outfit exposes all the secrets that have mystified you so long.

With one of these outfits you can give a complete entertainment of chemical magic that will fascinate and mystify. There's a big book in every out-

fit telling just how to do each trick, how to hold your hands when performing and all other necessary information. With a little practice you can soon be earning a good deal of extra spending money. The outfits contain a complete assortment of chemicals, some in liquid form in glass bottles, sealed with wax, and others in powder form in wooden containers. There are enough chemicals included with which to give a whole evening's entertainment. Packed in Gilbert Toy carton, size 18 x 10 x 1 1/4 inches. Approximate weight: 1 lb., 5 ozs., Price \$5.00 (Canada \$7.50).

## PHOTO PHADS

No. 2024

Gee! It's great to have a Photo-Phad set and transfer photographs and pictures to cloth, glass and paper. The boy or girl who sees a picture of a pretty landscape or other design can easily decorate a sofa pillow, a glass window, a cloth hanging, etc., with this new method. Then, too, it's possible, to print your own photograph on your letter paper. And best yet, is for the boy who wants to put his favorite photo on his watch. This can be done easily. The material in your outfit will make all your prints permanent, so you need not be afraid they will rub off.

Don't think you have to own a camera to enjoy this outfit. You can transfer photographs your friends have given you, or make copies from pictures in magazines and books. Packed in new Gilbert Toy carton, size, 18 x 10 x 1 1/4 inches. Approximate weight: 2 lbs., 12 ozs. Price \$2.50 (Canada \$3.75).



## MUTT & JEFF JOKES

No. 2008

Every boy knows about Bud Fisher's famous comedians, Mutt & Jeff. You fellows have had many a good laugh and thoroughly enjoyed the pranks these laugh-provokers are pictured doing in all the newspaper comic supplement pages.



Here's an outfit with which you can perform a great number of funny stunts such as the Sore Finger, Rubber Tack, Plate Lifter or Heart Palpitator, Ravelling Joke, Window or Plate Smasher and Magic Ink Spot. Packed in Gilbert Toy carton with book of

instructions telling you just how to do each one. Size of carton, 12 1/4 x 8 3/4 x 1 1/4 in. Approximate Weight: 1 lb. Price \$1.50 (Canada \$2.25).

## HANDKERCHIEF TRICKS

No. 2025

Contains a collection of clever and novel feats, such as you have seen the magicians perform on the stage.

With it is included a book of instructions telling you in a very simple way the manner in which each trick is prepared. The number of illustrations is large because every move that must be made is pictured so that you cannot misunderstand any direction given.

The outfit contains all the material you need to give a full evening's entertainment for your friends or your club. The set comes in Gilbert Toy carton, size 18 x 10 x 1 1/4 inches. Approximate Weight: 1 lb., 6 ozs. Price \$7.50 (Canada \$11.25).



## PUZZLE PARTIES

## No. 1029

A good puzzle to solve—one that is a corker and which will test your thinking power to the limit is about the most fun you could wish for, and the No. 1029 Gilbert Puzzle Party Set provides an entertainment for you and your friends which is hard to beat.

With the puzzles in this outfit, different games can be played and prizes given to the person solving the various puzzles first. Instructions for each trick telling just how to do them, come with each set which is packed in the Gilbert Toy carton. Price 25c (Canada 40c).

## No. 1030

No one really seems to know when, where, and how puzzles originated. In fact, the greatest puzzles in all Puzzledom is in regard to their origin. With the varied assortment in the No. 1030 Gilbert

Puzzle Set, your puzzle-solving ability will be tested to the limit. Outfit complete with Book of Instructions giving all necessary information and directions regarding all puzzles in set comes packed in the individual Gilbert Toy carton. Price 50c. (Canada 75c).

## No. 1031

Just imagine a dozen of your friends all seated around a big table, each with a different puzzle to solve and each one trying their best to win the prize that has been put up for the one who masters the puzzle first. There is nothing more fascinating than a good puzzle, and the fun there is in doing these tricks will keep you right on your toes every minute.

With the assortment of puzzles in the No. 1031 Set, a most enjoyable part can be had, and a special Book of instructions which comes with this outfit gives complete information about each individual puzzle. Packed in Gilbert Toy package. Price \$1.00 (Canada \$1.50).

## No. 1032

(Not Illustrated)

A complete assortment of all Gilbert puzzles is included in the No. 1032 Puzzle Party Outfit, the largest and most popular set we have ever made. A wonderful variety of tricks, each one being entirely different from the other. Not only is there that fascinating fun connected with the solving of all puzzles, but a good training in quick thinking as well, for to solve a puzzle it is necessary to think and think quickly and logically.

The Set is complete in every detail, and a great variety of tricks makes possible one grand big Puzzle Party.

Packed in Gilbert Toy carton with complete Book of Instructions. Price \$2.00 (Canada \$3.00).

## SIGNAL ENGINEERING

## No. 6544

What better sport could you have than that of sending messages by signals, using many different systems?

Gilbert Signal Engineering will teach you how to use the Heliograph, the Wig Wag, Ardois, the Semaphore, and other systems of signalling operated with such great success by the U. S. Army and Navy. Learn about the signals used by ships when out at sea. You will find that many times when out camping or hunting a knowledge of signals will be a great help to you. Suppose some night you and your friends are at camp, you can exchange messages by means of flash-light signals.

Contains two complete sets of electric signals with red and white electric lights with key-board for operating them. Has also 128 page book giving directions for using the set and instructions for making flags and other signals as well as telling you how to Wig Wag, use a Semaphore and Blinker. Gives codes and illustrations of many flags in four colors. Packed in Gilbert Toy carton, size 18 x 10 x 1¼ inches. Approximate weight, 3 lbs. Price \$10.00 (Canada \$15.00).

## No. 6541

A dandy little blinker set. Contains light and control key together with wire for connecting and book of instructions on Blinker Signalling. Packed in Gilbert Toy carton, size 18 x 10 x 1¼ inches. Approximate weight, 2 lbs. Price \$1.00 (Canada \$1.50).

# GILBERT TOY TIPS

The army of boys all over the world who have Gilbert Toys has grown so tremendously and there are so many new things come up every day that I have published a little magazine called "Gilbert Toy Tips." This is a magazine particularly for boys. It has some corking articles on athletics, camping, fishing, wireless telegraphy, chemistry and heaps of other things which I know boys are interested in. It also is the official magazine for the Gilbert Engineering Institute for Boys containing letters which boys have sent me together with their pictures and stories about things



ing me twenty-five cents to cover postage and wrapping, the rest of the expense I gladly stand myself. It is published eight times a year, in February, April, June, August, September, October, November and December. Send today for this great boys' paper.

they are doing. Many boys are sending me stories of their own to print in this magazine every month. Then too, there is a correspondence corner where boys can list their names and in that way get in touch with other boys all over the world. It is a cracker-jack boy's paper and you surely want to become a subscriber. You can get it for a whole year by simply sending

Cordially yours,  
*A.C. Gilbert*  
 President.